

LINEADIN®

**Canali portacavi e portautenze
con coperchi combinabili.**
*Cable ducting and socket point
systems with relevant covers.*



pagina / page

2.5.4

Dati tecnici.
Technical data.



pagina / page

2.5.8

LINEADIN LDCAB.

Elementi del sistema.

System components.

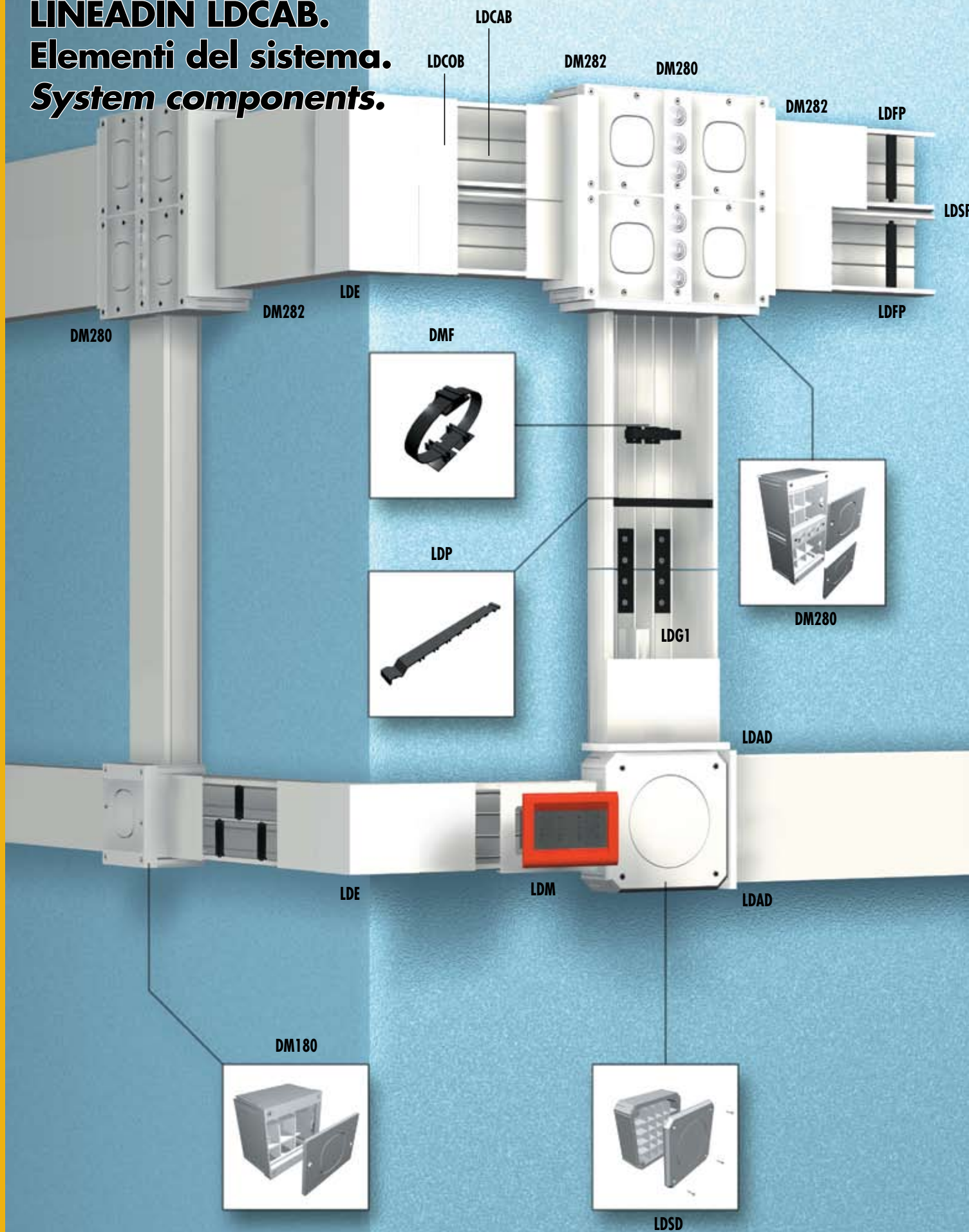

PU

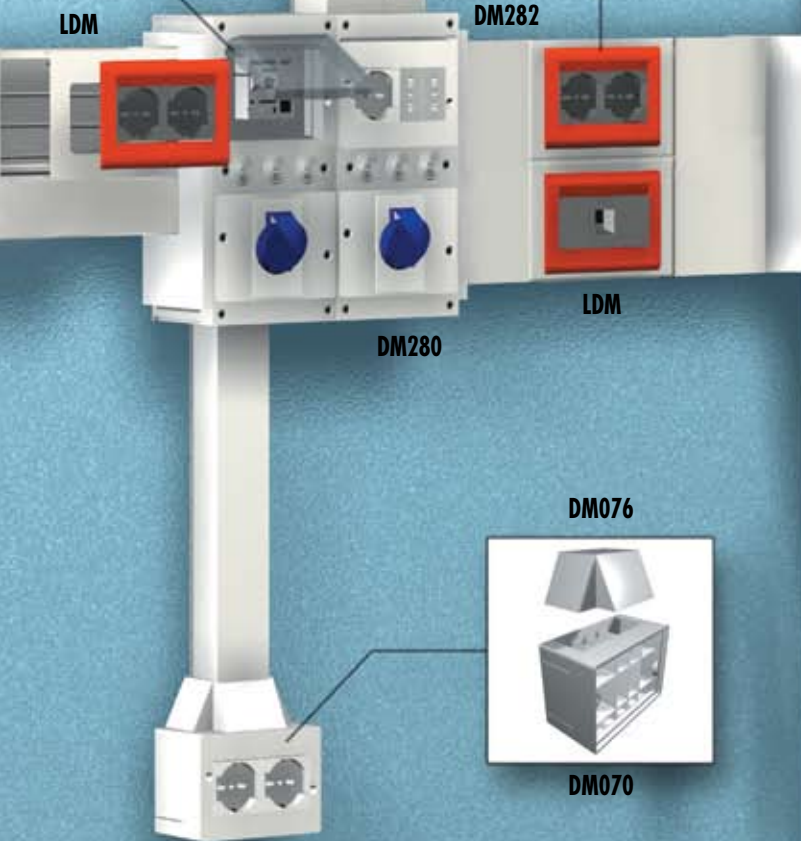
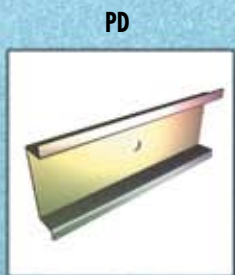

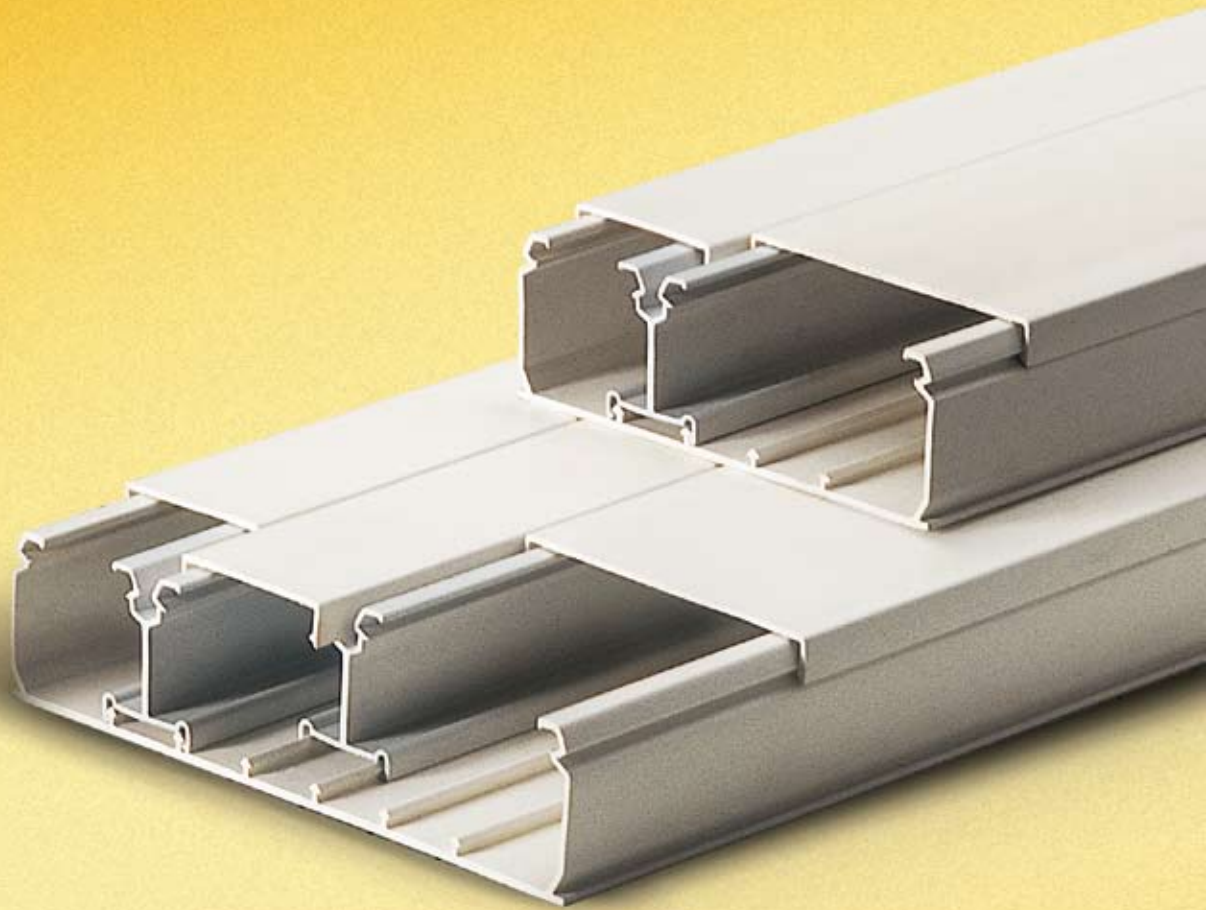

LINEADIN®

Canali portacavi e portautenze. Coperchi smontabili con attrezzo (usando LDFP).
Materiale: PVC Rigido Autoestinguente Classe 1 (UL94-VO).
Lunghezza: 2 metri

Cable trunkings and socket point systems. Covers removable by tool (using LDFP).
Self-extinguishing rigid PVC Class 1 (UL94-VO).
Length: 2 meters

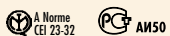

GWT = T850°

Codifica per l'ordine dei canali
Functional part numbering system

LD100CA

BEU

Tipo
Type

Colore
Colour

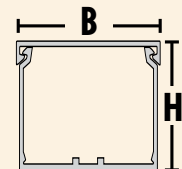

COLORI
COLOURS



BEU = Bianco / White
Type 9010



Coperchio liscio.
Smooth cover.

Canali portacavi e portautenze. Coperchi smontabili con attrezzo (usando LDFP).
Coperchio liscio. PVC Rigido Autoestinguente Classe 1 (UL94-VO).

Cable trunkings and socket point systems. Covers removable by tool (using LDPF).
Smooth cover. Self-extinguishing rigid PVC Class 1 (UL94-VO).

Guide	Sezione fondo	Tipo	Dimensioni BxH mm	Colore	Imballo m	S.G. mm ²	Lung. barre m	Cartone peso Kg
Rails	Section of the bottom	Part number	Duct Size BxH mm	Colour	Standard Carton m	G.S. mm ²	Length m	Carton Weight Kg
▲		LD100CA	100x50	BEU	24	4270	2	17,9
▲		LD150CA	150x50	BEU	12	6320	2	12,4
▲		LD200CA	200x50	BEU	12	8590	2	15,3

▲ Canali con guide sul fondo. Trunkings with rails on the bottom.

Sezione con guida Section with rail

Possibili combinazioni. / Possible combinations.

LD100CABEU

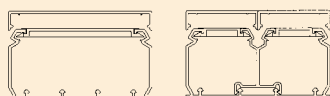

LD150CABEU

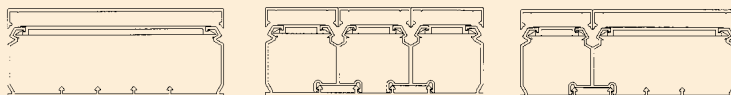

LD200CABEU

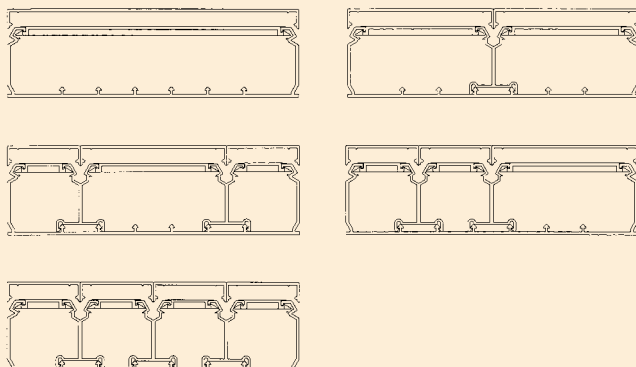

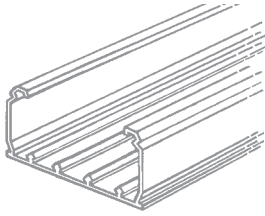

GWT = T850°

Guide	Tipo	Colore	BxH mm
Rails	Part number	Colour	BxH mm

▲	LD100CA	BEU	100x50
▲	LD150CA	BEU	150x50
▲	LD200CA	BEU	200x50

LD CO

Coperchio per canali portautenze LDCAB. Utilizzando il traversino di trattenuta cavi LD FP sono smontabili con attrezzo. Covers for socket point trunkings LDCAB. By using the cross arm for retaining cables LD FP they are dismantable by tool. Lunghezza/Length: 2 m

Tipo	Colore	Imballo m
Part number	Colour	Packing m

LD050CO	•	BEU	96
LD100CO	•	BEU	48
LD050CO	•	BEU	96
LD100CO	•	BEU	48
LD150CO	•	BEU	16
LD050CO	•	BEU	96
LD100CO	•	BEU	48
LD150CO	•	BEU	16
LD200CO	•	BEU	16

LD SP U

Parete interna per canali LDCAB per creare scomparti indipendenti. Consente l'accoppiamento di più coperchi LDCOB. Separator for trunkings LDCAB. It allows the connection of more LDCOB covers. Lunghezza/Length: 1 m Colore/Colour: Grigio/Grey

Tipo	Colore	Imballo m
Part number	Colour	Packing m

LDSPU	□	25
LDSPU	□	25
LDSPU	□	25

LD FP

Traversino per il trattenimento dei cavi e dei coperchi, e per l'irrigidimento delle pareti dei canali LDCAB. Utilizzare il traversino LD FP per smontabilità coperchio con attrezzo. The cross arm for retaining cables and covers, and for stiffening of trunkings' walls. Colore/Colour: Nero/Black

Tipo	Colore	Imballo pz.
Part number	Colour	Packing pcs.

LD FP 50	•	500 (5x100)
LD FP 100	■	200 (2x100)
LD FP 50	•	500 (5x100)
LD FP 100	•	200 (2x100)
LD FP 150	■	50
LD FP 50	•	500 (5x100)
LD FP 100	•	200 (2x100)
LD FP 150	•	50
LD FP 200	■	50

• Per canale combinato (vedi pag. 2.5.10). For combined trunking (see page 2.5.10)

LD I

Angolo interno. Inner bend.

Tipo	Colore	Imballo pz.
Part number	Colour	Packing pcs.

LD105I	BEU	15
LD155I	BEU	10
LD205I	BEU	4

LD L

Giunto per derivazione piana. L-joint for deviations.

Tipo	Colore	Imballo pz.
Part number	Colour	Packing pcs.

LD105L	BEU	10
LD155L	BEU	10
LD205L	BEU	4

LD T

Giunto derivazione a T. T-joint wall deviations.

Tipo	Colore	Imballo pz.
Part number	Colour	Packing pcs.

LD105T	BEU	15
LD155T	BEU	10
LD205T	BEU	8

LDM5

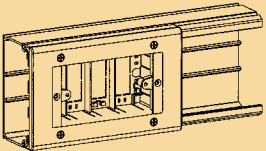

Mostrina per utenze mod. 503/504 e 506 per canali Lineadin 100-150-200 H 50.
Plate for Mod. 503/504 and 506 use for Lineadin trunkings 100-150-200 H 50.

Tipo	Colore	Imballo pz.
Part number	Colour	Packing pcs.

LDM100

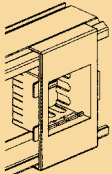

Mostrine per 2 moduli singoli o 1 Schuko per Vimar Plana (VIP) e Legrand Mos-Cross (LEG). Per canali Lineadin 100-150-200 H 50.
Plate for 2 single modules or for 1 Schuko for Vimar Plana (VIP) and Legrand Mos-Cross (LEG) for Lineadin trunkings 100-150-200 H 50.

Tipo	Colore	Imballo pz.
Part number	Colour	Packing pcs.

LDGR



Giunto coperchio.
Cover joint.

Tipo	Colore	Imballo pz.
Part number	Colour	Packing pcs.

LD E



Angolo esterno.
Outer bend.

Tipo	Colore	Imballo pz.
Part number	Colour	Packing pcs.

LDM504 LDM506	BEU	6 (1x6)
LDM504 LDM506	BEU	6 (1x6)
LDM504 LDM506	BEU	6 (1x6)

LDM100VIP LDM100LEG	BE	14 (2x7)
LDM100VIP LDM100LEG	BE	14 (2x7)
LDM100VIP LDM100LEG	BE	14 (2x7)

LDGR50 LDGR100	BEU	100 (5x20) 50 (5x10)
LDGR50 LDGR100	BEU	100 (5x20) 50 (5x10)
LDGR50 LDGR100	BEU	100 (5x20) 50 (5x10)

LD105E	BEU	15
LD155E	BEU	4
LD205E	BEU	4

LD A



Tappo terminale.
End cap.

Tipo	Colore	Imballo pz.
Part number	Colour	Packing pcs.

LDG1

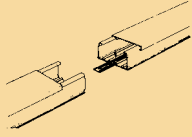

Giunto collegamento fondo canali. Utilizza viti autofilettanti (nella confezione).
Joint for connecting the base of the trunkings. Uses self-tapping screws (in the packing).
Colore/Colour: Nero/Black

Tipo	Colore	Imballo pz.
Part number	Colour	Packing pcs.

LDSD

Pag./Page 4.1.5

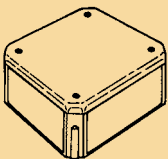

Scatola di derivazione per canali max 125x50, min 50x50 mm. Completa di separatori cavi e pareti laterali.
Junction box for trunkings max 125x50, min 50x50 mm. Complete with cable separation and wall sides.

Tipo	Colore	Imballo pz.
Part number	Colour	Packing pcs.

LDAD

Pag./Page 4.1.5

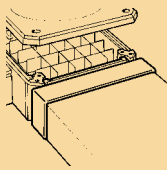

Per derivare dalla scatola LDSD canali LDC 150x50.
For junction between LDSD box and LDC trunkings 150x50.

Tipo	Colore	Imballo pz.
Part number	Colour	Packing pcs.

GT100A ▲	BEU	10
LD155A	BEU	10
LD205A	BEU	10

LDG1	■	25 (5x5)
LDG1	■	25 (5x5)
LDG1	■	25 (5x5)

LDSD	BEU	4
LDSD	BEU	4

LDAD	BEU	16
------	-----	----

▲ = Ricavare dalla misura più grande. Get from bigger sizes.

Dati tecnici. Technical data.

LDM504/506

Mostrina portautenze brevettata, per canali Lineadin LDCA, altezza 50. Si fissa sui bordi del canale.
Patented socket-point plate, for Lineadin trunkings height 50. It has to be fixed on the trunking sides.

Più spazio per i tuoi cablaggi.
More space for your cabling.

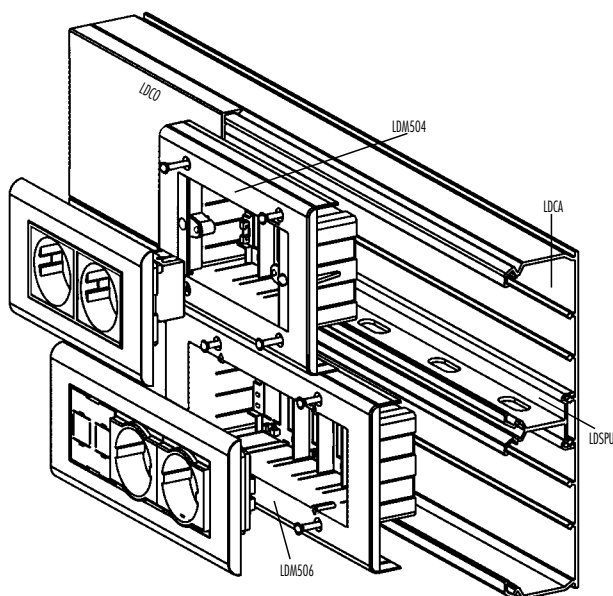

Sezione utile per passaggio cavi. / Useful section for cabling.

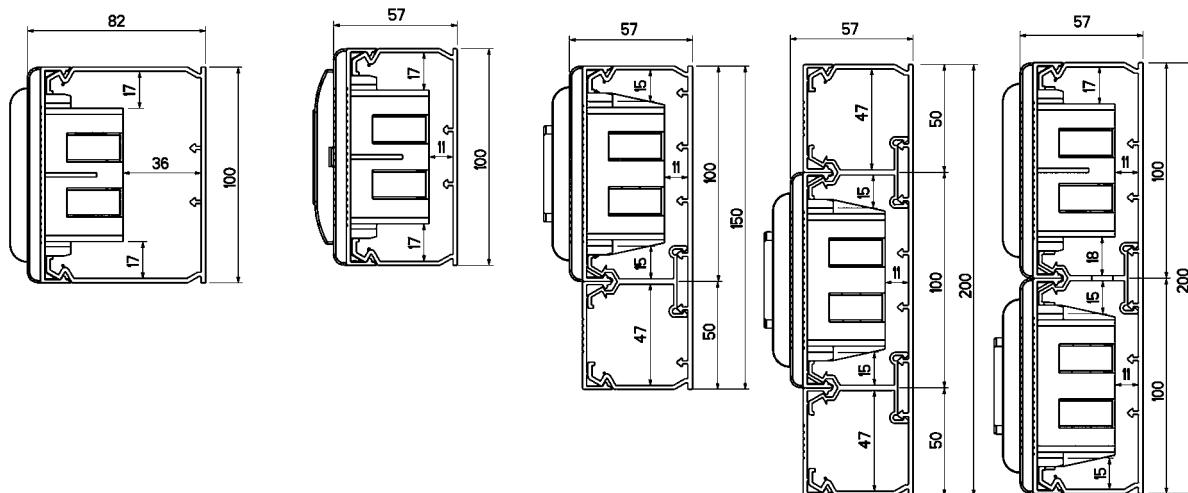

Risultati di prova. / Test results.

Il valore medio riscontrato della forza di estrazione, per il set di spine è risultato pari a 27,6N.
The medium pull-out force value checked for the sockets set results 27,6 N.



Verifica forza di estrazione della spina dalla presa 2P+T+T montata su mostrina LDM 504 ed applicata sul canale della serie Lineadin.
Check of the pull-out force for the socket 2P+T+T mounted on the plate LDM504 and applied on the Lineadin trunking.

Sequenza montaggio. / Mounting sequence.



Dati tecnici. Technical data.

Dimensioni e disposizione guide sul fondo per separatori. Sizes and layout of the rails on the bottom for the separators.

Canali portautenze che, con l'ausilio del separatore interno LDSPU e dei coperchi LDCA accoppiabili in diverse misure, consentono l'installazione di utenze mantenendo integralmente separate le linee passanti all'interno degli scomparti e rendendo possibile l'accesso indipendente allo scomparto desiderato.

Utilizzano coperchi pretranciati su cui si applicano direttamente le utenze fissate alle scatole portautenze.

Socket point trunkings that, thanks to the help of the internal separator LDSPU and covers LDCA that can be joined together in different sizes, allow the installation of socket points by keeping lines separate passing inside compartments and by permitting the independent access to the desired compartment.

They use the pre-cut covers on which they directly apply the equipments fixed on the socket point boxes.

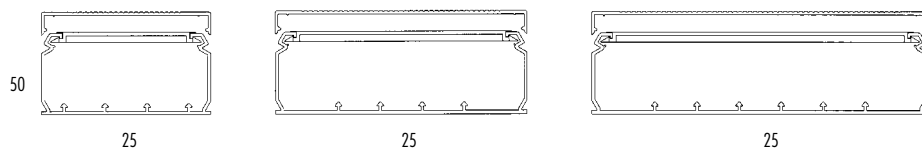

Base 100

150

200

Combinazioni possibili. Possible combination.

1 Canali portacavi e portautenze.
Cable ducting and socket point trunkings.

2 Canali portacavi.
Cable ducting.

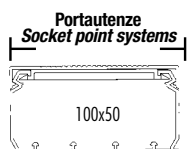

LD100CA

- + 1 LD100CO Coperchio/Cover
- + 1 LDFF100 Traversino/Cross arm

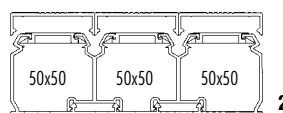

LD150CA

- + 3 LD050CO Coperchi/Covers
- + 3 LDFF50 Traversini/Cross arm
- + 2 LDSPU Separatori/Separators

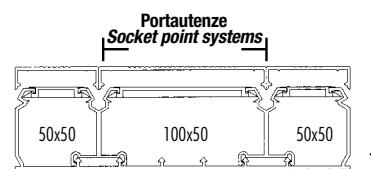

LD200CA

- + 1 LD100CO Coperchio/Cover
- + 1 LDFF100 Traversino/Cross arm
- + 2 LD050CO Coperchi/Covers
- + 2 LDFF50 Traversini/Cross arms
- + 2 LDSPU Separatori/Separators

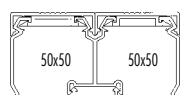

LD100CA

- + 2 LD050CO Coperchi/Covers
- + 2 LDFF50 Traversini/Cross arms
- + 1 LDSPU Separatore/Separator

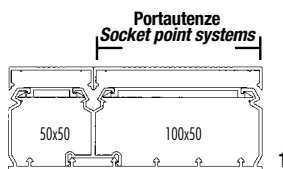

LD150CA

- + 1 LD100CO Coperchio/Cover
- + 1 LDFF100 Traversino/Cross arm
- + 1 LD050CO Coperchio/Cover
- + 1 LDFF50 Traversino/Cross arm
- + 1 LDSPU Separatore/Separator

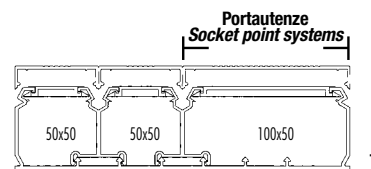

LD200CA

- + 1 LD100CO Coperchio/Cover
- + 1 LDFF100 Traversino/Cross arm
- + 2 LD050CO Coperchi/Covers
- + 2 LDFF50 Traversini/Cross arms
- + 2 LDSPU Separatori/Separators

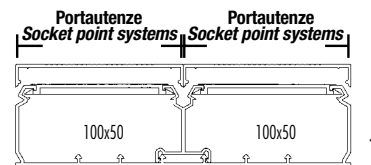

LD200CA

- + 2 LD100CO Coperchi/Covers
- + 2 LDFF100 Traversini/Cross arms
- + 1 LDSPU Separatore/Separator

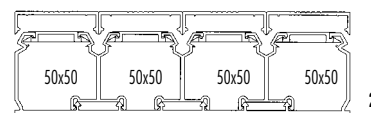

LD200CA

- + 4 LD050CO Coperchi/Covers
- + 4 LDFF50 Traversini/Cross arms
- + 3 LDSPU Separatori/Separators

LDSPU

Separatore per canali LDCA.
Separator for LDCA trunkings.

Fissato alla guida sul fondo dei canali LDCA, crea vari scomparti interni e diventa l'elemento di aggancio dei coperchi componibili LDCA.
Fixed to the rail on the bottom of the LDCA trunking, divides it in several internal compartments and it is the hooking element of the composed covers LDCA.

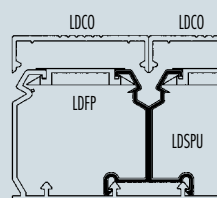
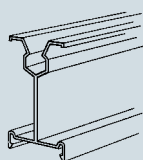

LDCA

