

# 5 Canali per il condizionamento. Air conditioning trunkings.

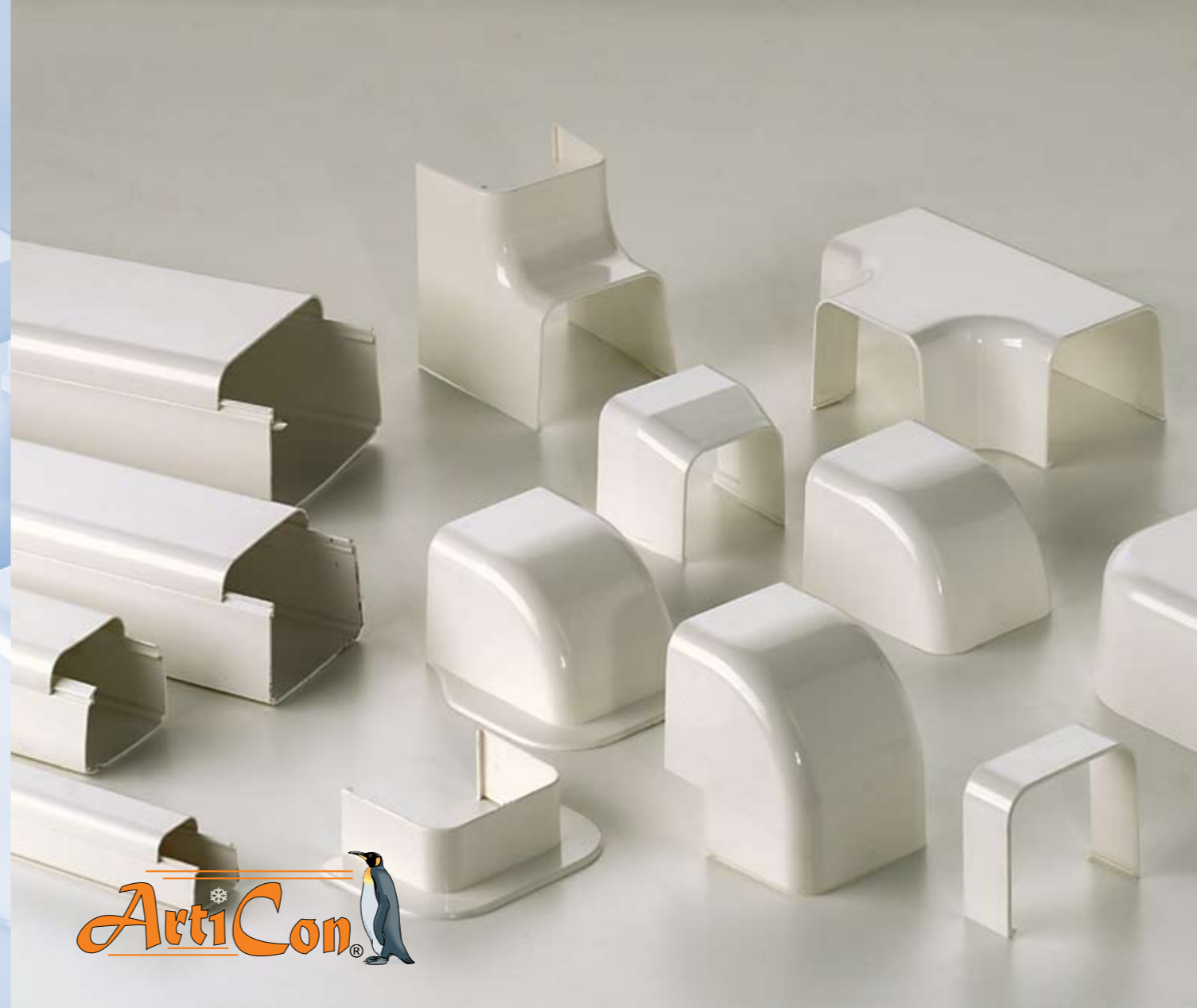

**Articon**

pag. 5.1.1

**Sistema di canali per il condizionamento.**  
*Air conditioning trunkings.*



pagina / page

5.1.4

**Accessori scarico condensa, basi e staffe.**  
*Accessories condensation drain, bases  
and brackets.*



pagina / page

5.1.8

**Pompe di aspirazione e condensa.**  
*Condensation and suction pumps.*



pagina / page

5.1.11

**Rame. Raccordi. Autocartellanti.**  
*Copper. Fittings. Self-outflaring.*

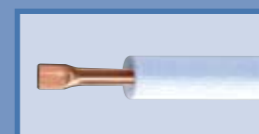

pagina / page

5.1.12

**Utensili. Strumentazione.**  
*Manometri e tubazioni. Utensili e ricambi.*  
*Tools. Instruments. Manometers and pipings.*  
*Tools and spare parts.*



pagina / page

5.1.14

# ARTICON. Elementi del sistema. System components.

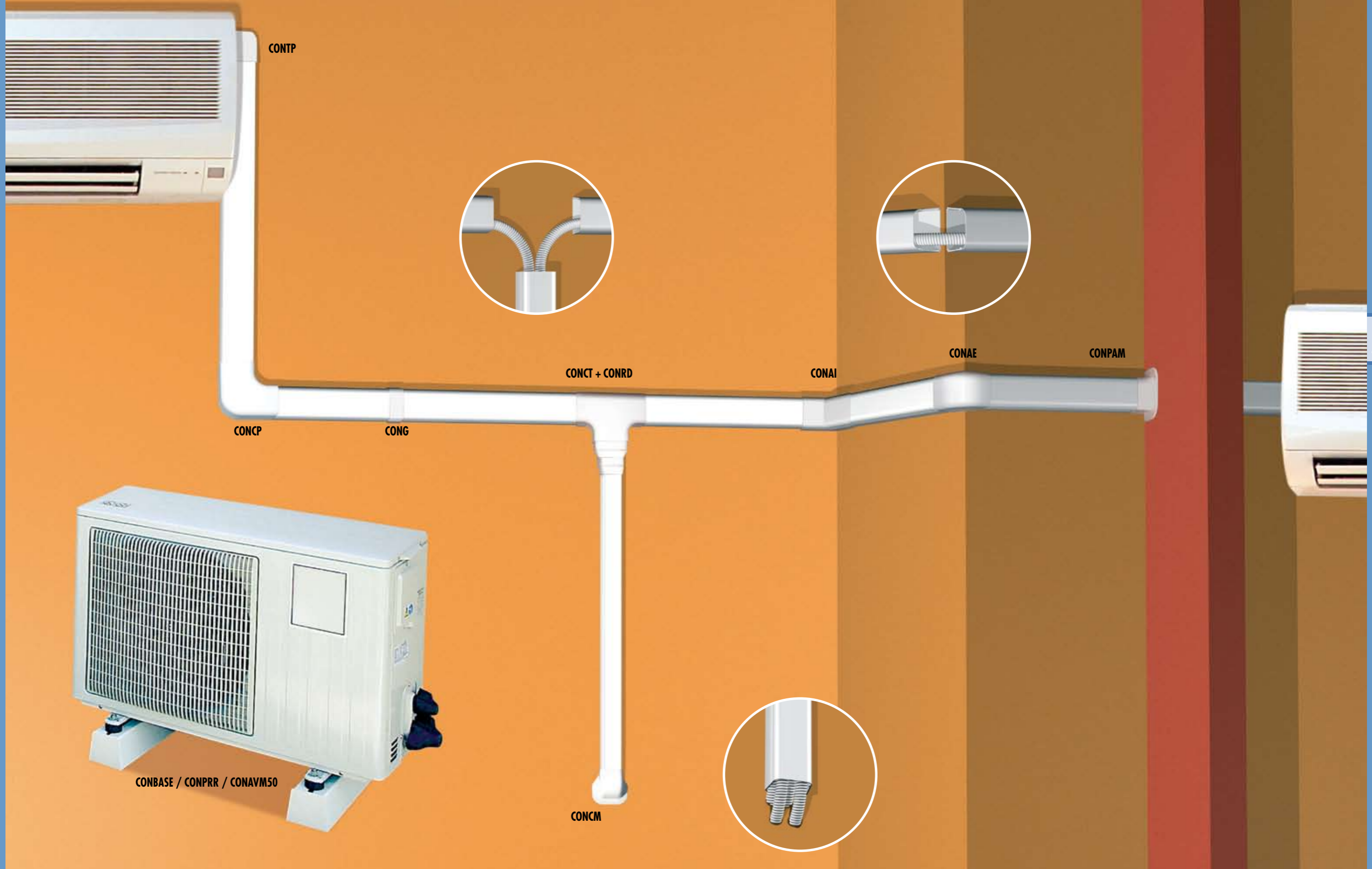



**Il nuovo traversino CONTR**, innestato forzatamente su un lato del canale, contiene in modo efficace tubi, cavi e scarichi di condensa, agevolando l'installazione. L'aggancio finale sul lato opposto consente un fissaggio del coperchio solido e sicuro.

**The new CONTR cross-arm** inserted on one side of the trunking, effectively contains pipes, hoses and condensation drainage while making installation easy. The final hooking on the opposite side allows a solid and safe cover fixing.



Nuovo sistema di aggancio che agevola l'inserimento a pressione del coperchio. *New snap-on system to allow an easier cover snap-on.*

Nuovo sistema di aggancio per una maggiore solidità del traversino. *New snap-on system for a better stiffness of the cross-arm.*

Nuovo sistema di aggancio del traversino per una perfetta tenuta. *New snap-on cross-arm system for a perfect hold.*



Sistema di canali per il condizionamento. Materiale: PVC Rigido stabilizzato UV, Autoestinguente Classe 1 (UL94-VO). *Air conditioning trunkings. Self-extinguishing PVC, UV stabilized Class 1 (UL94-VO).*

Tipo	Dimensioni BxH mm	Colore	Imballo m	S.G. mm <sup>2</sup>	Lung. barre m	Cartone peso Kg
Part number	Duct Size BxH mm	Colour	Standard Carton m	G.S. mm <sup>2</sup>	Length m	Carton Weight Kg
CON30	35x30	M	64	810	2	15,0
CON70	70x55	M	24	3180	2	15,4
CON90	90x65	M	16	4830	2	14,5
CON125	125x75	M	8	8390	2	9,5



Sistema di canali per il condizionamento. Materiale: PVC Rigido stabilizzato UV, Autoestinguente Classe 1 (UL94-VO). Lunghezza: 2 metri

*Air conditioning trunkings. Self-extinguishing PVC, UV stabilized Class 1 (UL94-VO). Length: 2 meters*



**Codifica per l'ordine dei canali**  
**Functional part numbering system**

**CON30**      **M\***

Tipo              Colore  
Type              Colour

- I canali vengono forniti completi di coperchio.
- All trunkings come complete with cover.
- \* Indicare solo quando il colore richiesto è diverso da Bianco.
- \* Indicate only when the requested colour is different from white.

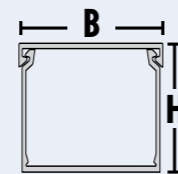

**COLORI COLOURS**

= Bianco / White type 9010

M = Marrone / Brown type 8017

**Sezioni utili / Working sections**

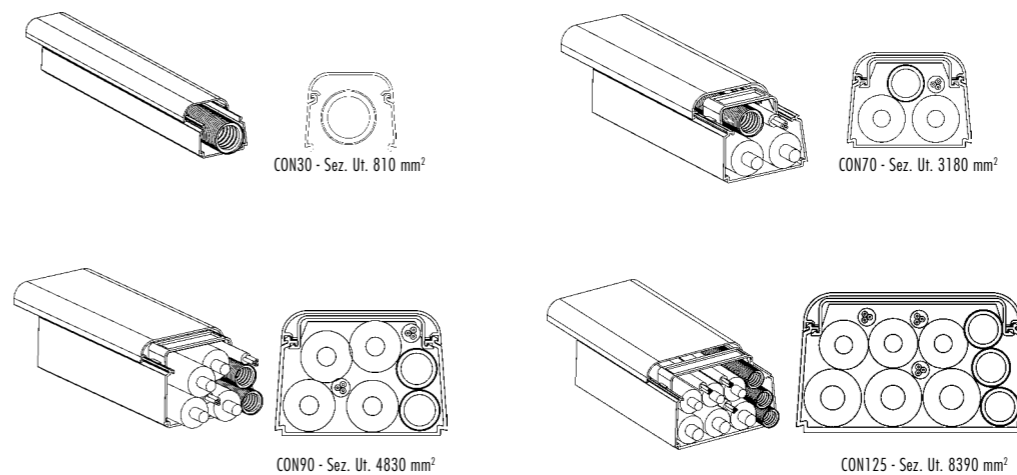

**Foratura ARTICON. ARTICON holes.**

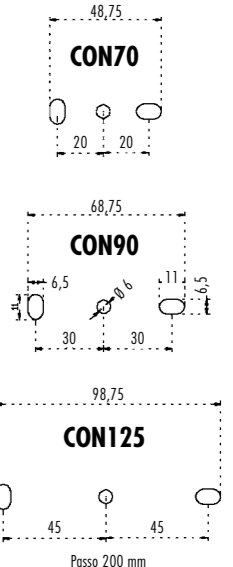

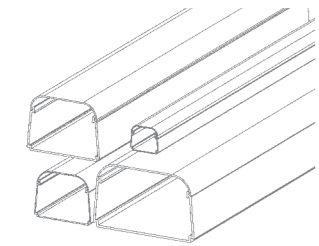

AM50

Tipo	BxH mm
Part number	BxH mm

CON30	35x30
CON70	70x55
CON90	90x65
CON125	125x75

**CONPTB**

Set portabolla + bolla.  
Spirit level holder + spirit level set.

Tipo	Colore	Imballo pz.
Part number	Colour	Packing pcs.

CONPTB		50
CONPTB		50
CONPTB		50

**CONTR TB**

Traversino.  
Cross-arm.

Tipo	Colore	Imballo pz.
Part number	Colour	Packing pcs.

CONTR70TB	■	25
CONTR90TB	■	25
CONTR125TB	■	25

**CONG**

Giunto coperchio.  
Cover joint.

Tipo	Colore	Imballo pz.
Part number	Colour	Packing pcs.

CONG30	□ - M	25
CONG70	□ - M	25
CONG90	□ - M	25
CONG125	□ - M	25

**CONGU**

Giunto con guarnizione.  
Joint with seal.

Tipo	Colore	Imballo pz.
Part number	Colour	Packing pcs.

CONGU70	□	10
CONGU90	□	10

**CONPAM**

Passaggio a muro.  
Wall routing.

Tipo	Colore	Imballo pz.
Part number	Colour	Packing pcs.

CONPAM70	□ - M	10
CONPAM90	□ - M	10

**CONTP**

Tappo terminale.  
End cap.

Tipo	Colore	Imballo pz.
Part number	Colour	Packing pcs.

CONTP30	□ - M	20
CONTP70	□ - M	10
CONTP90	□ - M	10
CONTP125*	□ - M	10

**CONCM**

Curva a muro.  
Wall bend.

Tipo	Colore	Imballo pz.
Part number	Colour	Packing pcs.

CONCM70	□ - M	10
CONCM90	□ - M	10

**CONAI**

Angolo interno.  
Inner bend.

Tipo	Colore	Imballo pz.
Part number	Colour	Packing pcs.

CONAI30	□ - M	20
CONAI70	□ - M	10
CONAI90	□ - M	10
CONAI125	□ - M	10

**CONAE**

Angolo esterno.  
Outer bend.

Tipo	Colore	Imballo pz.
Part number	Colour	Packing pcs.

CONAE30	□ - M	20
CONAE70	□ - M	10
CONAE90	□ - M	10
CONAE125	□ - M	10

**CONCP**

Curva piana.  
Flat bend.

Tipo	Colore	Imballo pz.
Part number	Colour	Packing pcs.

CONCP30	□ - M	20
CONCP70	□ - M	10
CONCP90	□ - M	10
CONCP125	□ - M	10

**CONRD**

Riduzione.  
Reduction.

Tipo	Colore	Imballo pz.
Part number	Colour	Packing pcs.

CONRD90	□ - M	10
CONRD125	□ - M	10

**CONCT**

Derivazione a "T".  
T-joint deviation.

Tipo	Colore	Imballo pz.
Part number	Colour	Packing pcs.

CONCT90	□ - M	6
CONCT125	□ - M	6

**CONVG**

Convogliatore a parete.  
Flange accessory.

Tipo	Colore	Imballo pz.
Part number	Colour	Packing pcs.

CONVG110-90	□	8
-------------	---	---

# Accessori. Scarico condensa. Accessories. Condensation drain.

## CONBOX43E

Cassetta modulare Economica per scarico condensa.  
Cheap Modular box for condensation drain.

Tipo	Dimensioni mm	Imballo pz.
Part number	Dimensions mm	Packing pcs.
CONBOX43E	455x105x65	24



Box predisposto per montaggio con uscita scarico condensa orizzontale posizionabile sia a destra che a sinistra.  
Box designed for assembly with horizontal condensate drain which can be positioned either on the right or left.

## CONBOX

Cassetta modulare per scarico condensa.  
Modular box for condensation drain.

Tipo	Dimensioni mm	Imballo pz.
Part number	Dimensions mm	Packing pcs.
CONBOX	525x105x68	24
CONBOX430	430x103x68	24



Box predisposto per scarico condensa integrato posizionabile a destra o sinistra.  
Box designed for assembly with horizontal condensate drain which can be positioned either on the right or left.

## CONBOXRC

Raccordo scarico 90°.  
90° connection drain.

Tipo	Dimensioni mm	Imballo pz.
Part number	Dimensions mm	Packing pcs.
CONBOXRC	Ø 16/18/20	48



90° per uscita scarico verticale da applicare alla cassetta modulare  
90° for a vertical drain to be attached to the modular box.

## CONRAC283

Raccordo a tre vie.  
Three-way fitting.

Tipo	Dimensioni mm	Imballo pz.
Part number	Dimensions mm	Packing pcs.
CONRAC283	Ø 16/18/20	50

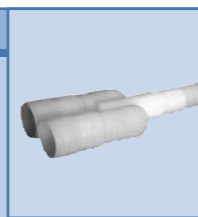

Con impianti multi-split.  
Conduce lo scarico di due macchine ad un'unica tubazione  
With multi-split systems. Conveys the drain of two machines to single piping.

## CONFLBI

Tubo spiralato in PVC plastificato autoestinguento V0 - secondo UNI CIG7129/93.  
PVC hose self-extinguishing V0- according to UNI CIG7129/93.

Tipo	Dimensioni mm	Imballo m.
Part number	Dimensions mm	Packing m.
CONFLBI16	Ø 16	25
CONFLBI18	Ø 18	25
CONFLBI20	Ø 20	25



L'interno liscio evita ristagni di condensa. Temperatura d'impiego -20° + 65°. Non usare con acqua calda.  
Specifically recommended for systems in conduits, particularly resistant to crushing. Working temperature -20° + 65°. Do not use hot water.

## CONFLEX

Tubo flessibile parete semplice corrugata.  
Corrugated hose.

Tipo	Dimensioni mm	Imballo m.
Part number	Dimensions mm	Packing m.
CONFLEX18	Ø 16/18	50
CONFLEX20	Ø 18/20	50



Specificatamente indicato per impianti sottotraccia, particolarmente resistente allo schiacciamento. Materiale P.P.  
Specifically suitable for recess systems, strong resistance to crushing. Material PP.

## CONISO

Nastro isolante anticondensa.  
Anti-condensation insulating tape.

Tipo	Dimensioni mm	Imballo pz.
Part number	Dimensions mm	Packing pcs.
CONISOGM	50x3 - 10 m	24
CONISOPL	50x3 - 10 m	24



Materiale: Gomma = GM Polietilene = PL  
Campo di impiego: -15°C/+80°C - Reazione al fuoco Classe 1.  
Material: Rubber = GM Polyethylene = PL  
Range of use: -15°C/+80°C. - Class 1 fire reaction.

## CONBAC

Bacinella raccoglicondensa.  
Condensate tray.

Tipo	Dimensioni mm	Imballo pz.
Part number	Dimensions mm	Packing pcs.
CONBAC1	790x390x30	5
CONBAC2	940x420x30	5



Adattabile a tutti i tipi di staffe in commercio.  
Can be adapted to all types of brackets available on the market.

## CONPRR

Protezione rubinetti.  
Protection of valves.

Tipo	Dimensioni mm	Imballo pz.
Part number	Dimensions mm	Packing pcs.
CONPRR	1/2" , 1/4"	24 coppie/couples



Per rubinetti gas freon e per unità esterne.  
For freon gas valves and for outdoor units.

## CONRACCT1620

Raccordo scarico cassetta-tubo.  
Box-hose drain connection.

Tipo	Dimensioni mm	Imballo pz.
Part number	Dimensions mm	Packing pcs.
CONRACCT1620	16x20	30



## CONRACY

Raccordo scarico "Y".  
"Y" drain connection.

Tipo	Dimensioni mm	Imballo pz.
Part number	Dimensions mm	Packing pcs.
CONRACY1618	Ø 16/18	10
CONRACY1820	Ø 18/20	10

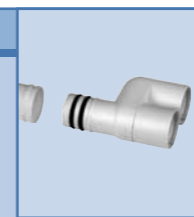

## CONRACT

Raccordo scarico "T".  
"T" drain connection.

Tipo	Dimensioni mm	Imballo pz.
Part number	Dimensions mm	Packing pcs.
CONRACT1618	Ø 16/18	10
CONRACT1820	Ø 18/20	10

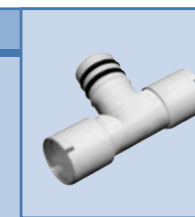

## CONSCCEST

Scatola copritubo per predisposizione esterna.  
Hose cover box for outdoor arrangement.

Tipo	Dimensioni mm	Imballo m.
Part number	Dimensions mm	Packing m.
CONSCCEST	710x165x80	1

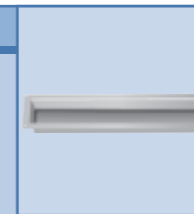

## CONSSC

Sifone scarico condensa verticale.  
Vertical siphon for condensation drain.

Tipo	Imballo m.
Part number	Packing m.
CONSSC146	50
CONSSCP146*	50

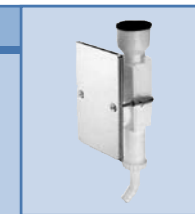

\*CONSSCP146 comprensivo di piastra di fissaggio 1" x 46.  
\*CONSSCP146 complete with fastening plate 1" x 46

## CONSSCU

Sifone scarico condensa orizzontale.  
Horizontal siphon for condensation drain.

Tipo	Imballo pz.
Part number	Packing pcs.
CONSSCU	50

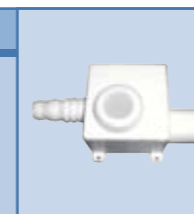

# Accessori. Basi e staffe. Accessories. Bases and brackets.

## CONBASE

Basi a pavimento.  
Floor bases.

Tipo	Dimensioni mm	Imballo pz.
Part number	Dimensions mm	Packing pcs.
CONBASE	420x120x72,5	2

Per unità esterne, in PVC, resistenti ai raggi UV e alle alte temperature.  
In PVC, for outdoor units, resistant to UV rays and to high temperatures.



Basi a pavimento.  
Floor bases.

Tipo	Dimensioni mm	Imballo pz.
Part number	Dimensions mm	Packing pcs.
CONBASE35	350x90x80	12 (6x2)
CONBASE45	450x90x80	12 (6x2)

Per unità esterne, in PVC, resistenti ai raggi UV e alle alte temperature.  
In PVC, for outdoor units, resistant to UV rays and to high temperatures.



## CONSTUN

Staffa universale regolabile completa di accessorio livella.  
Universal adjustable bracket complete with level accessory.

Tipo	Dimensioni mm	Imballo pz.
Part number	Dimensions mm	Packing pcs.
CONSTUN38	380x360x800	1
CONSTUN45	450x360x800	1

Regolabili per carichi distribuiti fino a 100 kg  
Le mensole sono verniciate con polveri epossidiche - in Bianco, testate e certificate TÜV Rheinland GS.  
Adjustable for distributed loads up to 80 kg - The brackets are painted with epoxy powders in white and tested and certified by TÜV Rheinland GS.

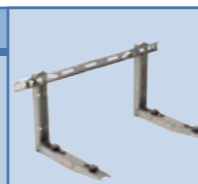

Staffe universali regolabili.  
Adjustable all-purpose brackets.

Tipo	Dimensioni mm	Imballo pz.
Part number	Dimensions mm	Packing pcs.
CONSTUN100	450x800	1

Regolabili per carichi distribuiti fino a 100 kg  
Le staffe sono verniciate con polveri epossidiche - in Bianco, testate e certificate TÜV Rheinland GS.  
Adjustable for distributed loads up to 100 kg - The brackets are painted with epoxy powders in white, and tested and certified by TÜV Rheinland GS.



## CONSTRO48

Staffa a tetto.  
Roof bracket.

Tipo	Dimensioni mm	Imballo pz.
Part number	Dimensions mm	Packing pcs.
CONSTRO48	1000x450	1

Staffa a tetto regolabile. Portata 140 kg unif. distrib. - Gradi di inclinazione 10°-40°.  
Le staffe sono verniciate con polveri epossidiche in Bianco, testate e certificate TÜV Rheinland GS.  
Adjustable roof bracket. Capacity 140 kg evenly distributed.  
The brackets are painted with epoxy powders in white, and tested and certified by TÜV Rheinland GS.



## CONSTPAR

Coppia staffe a parete.  
Pair of wall brackets.

Tipo	Dimensioni mm	Imballo pz.
Part number	Dimensions mm	Packing pcs.
CONSTPAR38*	380x360	1 coppia
CONSTPAR45*	450x360	1 coppia
CONSTPAR52**	520x400	1 coppia

\*38 e 45 = 150 kg \*\*52 = 120 kg  
Le staffe sono verniciate con polveri epossidiche - in Bianco, testate e certificate TÜV Rheinland GS.  
\*38 and 45 = 80 kg \*\*52 = 120 kg  
The brackets are painted with epoxy powders in white and tested and certified by TÜV Rheinland GS.



## CONAVM

Kit Antivibranti per mensola.  
Bracket anti-vibration kits.

Tipo	Dimensioni mm	Imballo pz.
Part number	Dimensions mm	Packing pcs.
CONAVM30	26x20	10 conf. (4pz)
CONAVM53	30x40	10 conf. (4pz)



## CONAVP20

Kit Antivibranti per pavimenti.  
Floor anti-vibration kits.

Tipo	Dimensioni mm	Imballo pz.
Part number	Dimensions mm	Packing pcs.
CONAVP20	48x20	10 conf. (4pz)



## CONAVP53

Kit Antivibranti per pavimenti Tp550.  
Tp550 floor anti-vibration kits.

Tipo	Dimensioni mm	Imballo pz.
Part number	Dimensions mm	Packing pcs.
CONAVP53	30x40	10 conf. (4pz)



## CONCPREST

Predisposizione esterna da incasso completa di piastre di fissaggio.  
Outdoor built-in arrangement complete with fastening plates.

Tipo	Dimensioni mm	Imballo pz.
Part number	Dimensions mm	Packing pcs.
CONCPREST	500x630x80	5



## CONCAP

Cappottina.  
Hood.

Tipo	Dimensioni mm	Imballo pz.
Part number	Dimensions mm	Packing pcs.
CONCAP725	700x265x540	10
CONCAP825	800x265x540	10
CONCAP836	860x330x610	10
CONCAP936	950x330x610	10
CONCAP937	950x380x750	10



# Pompe di aspirazione e condensa. Condensation and suction pumps.

## CONMAP

Pompa aspirazione condensa 15W.  
15W Condensation suction pump.

Tipo	Dati	Imballo pz.
Part number	Data	Packing pcs.
CONMAP8	16W 8m 10lt.	1
CONMAP8LG	16W 8m 10lt.	1

CONMAP8: Portata d'acqua: 10 litri/ora con prevalenza zero  
Livello di rumorosità: 21dB(A) con prevalenza > 1m  
CONMAP8LG: pompa aspirazione per climatizzatore LG ARTCOOLGALLERY.  
Portata d'acqua: 10 litri/ora con prevalenza zero. Livello di rumorosità: 21dB(A) con prevalenza > 1m  
CONMAP8: Water flow rate: 10 litres/hr @ zero head  
Noise 21dB(A) @ 1m & 10m head  
CONMAP8LG: Suction pump for air conditioner LG ARTCOOLGALLERY.  
Water flow rate: 10 litres/hr @ zero head. Noise 21dB(A) @ 1m & 10m head

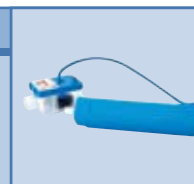

Pompa aspirazione condensa.  
Condensation suction pump.

Tipo	Dati	Imballo pz.
Part number	Data	Packing pcs.
CONMAP10	18W 10m 12lt.	1

Portata d'acqua: 12 litri/ora con prevalenza zero. Livello di rumorosità: 23dB(A) con prevalenza > 1m  
Water flow rate: 12 litres/hr @ zero head. Noise 23dB(A) @ 1m & 10m head

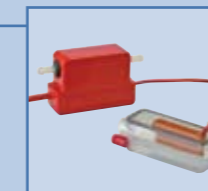

Pompa aspirazione condensa.  
Condensation suction pump.

Tipo	Dati	Imballo pz.
Part number	Data	Packing pcs.
CONMAP110	16W 10m 10lt.	1
CONMAP226	21W 20m 26lt.	1

CONMAP110: Portata acqua: 10 litri/ora con prevalenza zero. Livello di rumorosità: 23dB(A) con prevalenza > 1m  
CONMAP226: Portata d'acqua: 26 litri/ora con prevalenza zero. Livello di rumorosità: 35 dB(A) con prevalenza > 1m  
CONMAP110: Water flow rate: 10 litres/hr @ zero head. Noise 23dB(A) @ 1m & 10m head  
CONMAP226: Water flow rate: 26 litres/hr @ zero head. Noise 35dB(A) @ 1m & 10m head

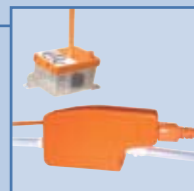

## CONMAPE

Pompa aspirazione condensa.  
Condensation suction pump.

Tipo	Dati	Imballo pz.
Part number	Data	Packing pcs.
CONMAPE46	11W 4m 6lt.	1
CONMAPE112	16W 10m 12lt.	1

CONMAPE46: Portata d'acqua: 6 litri/ora con prevalenza zero. Livello di rumorosità: 18dB(A) con prevalenza > 1m  
CONMAPE112: Portata d'acqua: 12 litri/ora con prevalenza zero. Livello di rumorosità: 21 dB(A) con prevalenza > 1m  
CONMAPE46: Water flow rate: 6 litres/hr @ zero head. Noise 18dB(A) @ 1m & 10m head  
CONMAPE112: Water flow rate: 12 litres/hr @ zero head. Noise 21dB(A) @ 1m & 10m head



## CONMAPS

Pompa con serbatoio. Pump with tank.

Tipo	Dati	Imballo pz.
Part number	Data	Packing pcs.
CONMAPS05	0,5lt. 3,5m 180lt.	1
CONMAPS20	2lt. 4,6m 288lt.	1

CONMAPS05: Capacità del serbatoio: 0,5 litri. Portata d'acqua: 180 litri/ora con prevalenza zero. Livello di rumorosità: 18dB(A) con prevalenza > 1m. Valvola di non ritorno di serie. CONMAPS20: Capacità del serbatoio: 2 litri. Portata d'acqua: 288 litri/ora con prevalenza zero. Livello di rumorosità: 18dB(A) con prevalenza > 1m. Valvola di non ritorno di serie.  
CONMAPS05: Tank capacity: 0,5 litres. Water flow rate: 180 litres/hr @ zero head. Noise 18dB(A) @ 1m & 10m head current non-return valve. CONMAPS20: Tank capacity: 2 litres. Water flow rate: 288 litres/hr @ zero head. Noise 18dB(A) @ 1m & 10m head. Current non-return valve.



## CONMAPP

Pompa peristaltica.  
Peristaltic pump.

Tipo	Dati	Imballo pz.
Part number	Data	Packing pcs.
CONMAPP625	12m 6,25lt.	1

Portata d'acqua: 6,25 litri/ora con prevalenza 12 metri dotata di 2 sensori in grado di rilevare differenziale temp. (min 5°C) dotata di temporizzatore per spegnimento ritardato di 3 minuti.  
Water flow rate: 6,25 litres/hr @ 12 metres head Equipped with 2 sensors able to take temperature differential (min 5°C) Equipped with timer for 3 minutes delayed turn off.



## CONFIL

Filtro in linea per pompe manicotto mm16.  
In-line filter for pumps sleeve 16mm.

Tipo	Imballo m
Part number	Packing m
CONFIL	5

Accessorio per pompe serie CONMAP8/8LG - CONMAP110 - CONMAP226.  
Accessory for pumps of CONMAP8/8LG - CONMAP110 - CONMAP226

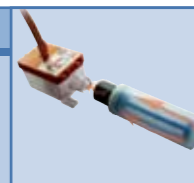

## CONVNR

Valvole di non ritorno.  
Non-return valves.

Tipo	Dimensioni	Imballo pz.
Part number	Dimensions	Packing pcs.
CONVNR14	1/4	5
CONVNR38	3/8	5



## CONTF

Tubo trasparente flex per condensa Ø 6x9.  
Transparent hose for condensation discharge Ø 6x9.

Tipo	Imballo m
Part number	Packing m
CONTF69	25

Per unità esterne, in PVC, resistenti ai raggi UV e alle alte temperature.  
In PVC, for outdoor units, resistant to UV rays and to high temperatures.

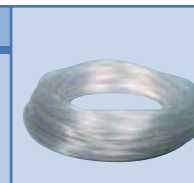

## CONPUM

Pompa aspirazione condensa per climatizzatori con poco spazio interno e potenza frigorifera non oltre 10kW.  
Blocco pompa e sistema di rilevazione a galleggiante.  
Condensation suction pump for air-conditioners with little inner space and chilling power ≤ 10kW.  
Pump stop and sensing system by ballcock.

Tipo	Portata	Imballo pz.
Part number	Capacity	Packing pcs.
CONPUM6	10 lt. - 6 m.	1

Alimentazione	230V 50/60 Hz 10W
Portata massima	10 l/h
Max capacity	10 l/h
Max Aspirazione	1,5 m
Max Suction	1,5 m
Max Spinta	6 m
Max Push	6 m
Dimensioni / Dimensions	
Blocco pompa	mm 58x42x55 h
Pump stop	mm 58x42x55 h
Blocco rilevazione	mm 55x40x35 h
Sensing stop	mm 55x40x35 h

Simulazione installazione pompa  
Pump installation simulation

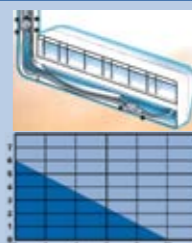

# Rame. Copper.

## Monotubo rame. Single copper pipe.

Monotubo rame preisolato per condizionamento. Idoneo R407/R410  
Pre-insulated single copper pipe for air-conditioning. Suitable for R407/R410.

Tipo Part number	Descrizione Description	Spessore Size	Imballo m. Packing m.
CUPP140	TUBO Riv. Godronato-Knurled coating 1/4"	0,80	50
CUPP380	TUBO Riv. Godronato-Knurled coating 3/8"	0,80	50
CUPP120	TUBO Riv. Godronato-Knurled coating 1/2"	0,80	50
CUPP141	TUBO Riv. Godronato-Knurled coating 1/4"	1	50
CUPP381	TUBO Riv. Godronato-Knurled coating 3/8"	1	50
CUPP121	TUBO Riv. Godronato-Knurled coating 1/2"	1	50
CUPP581	TUBO Riv. Godronato-Knurled coating 5/8"	1	25
CUPP341	TUBO Riv. Godronato-Knurled coating 3/4"	1	25

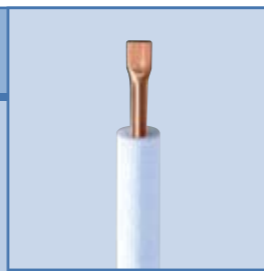

## Dati tecnici / Technical data

## Specifica pallet / Pallet Specification

Tipo Part number	metri rotolo m/roll	n° rotoli per pallet n°rolls/pallet	metri per pallet m/pallet	peso pallet Kg. Pallet weight Kg.	Dimensioni pallet cm. Pallet dimension cm.	Volume pallet m³ Pallet volume m³
CUPP140	50	18	900	130	75x75x220	1,24
CUPP141	50	18	900	155	75x75x220	1,24
CUPP380	50	15	750	165	75x75x220	1,24
CUPP381	50	15	750	200	75x75x200	1,24
CUPP120	50	15	750	210	75x75x200	1,24
CUPP121	50	15	750	245	75x75x200	1,24
CUPP581	25	18	450	205	75x75x200	1,24
CUPP341	25	16	400	255	75x75x200	1,24

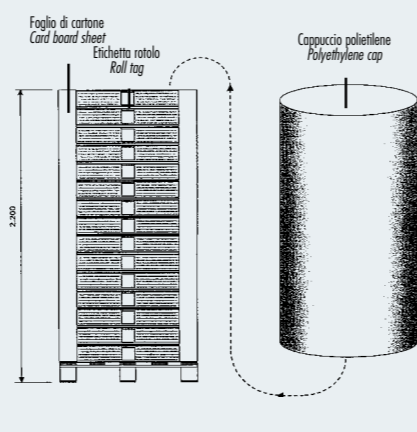

Foglio di cartone cm 200 x 220  
Card board cm 200 x 220

Pallet 75 x 75 cm  
Pallet 75 x 75 cm

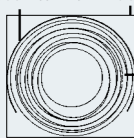

Rotolo tubo  
Pipe roll

Composizione pallet  
vista dall'alto  
Pallet layout  
view from top

## Specifica tubo rame / Copper pipe specification

Tubo Rame preisolato LWC EN 12735/1 - 1Cu/DHP 99,9% idoneo per gas ecologici R407 e R410. Isolamento: in polietilene espanso c.c.b.d. secondo L. 10/91, autoestinguente Classe 1 e conforme L. 46/90, anticorrosione, atossico, esente da CFC. Finitura: godronata per un'ottima tenuta nella segregazione in sottotraccia.

Colore: bianco Spessore tubo rame: 0,80 - 1 mm. Spessore isolamento: 6,5 - 10 mm. Temperatura d'impiego: -80°C +98°C Densità isolamento: 45 kg/m³

Pre-insulated copper pipe LWC EN 12735/1 - 1Cu/DHP 99,9% suitable for ecological gases R407 e R410. Insulation: foam polyethylene according to L. 10/91, self extinguishing Class 1 and conforming to L. 46/90, anticorrosion, non-toxic, CFC free. Finishing: knurled for optional wall embedding.

Colour: white Copper pipe thickness: 0,80 - 1 mm. Insulation thickness: 6,5 - 10 mm. Working temperature: -80°C +98°C Insulating density: 45 kg/m³

Dimensione tubo mm Pipe dimension mm	Dim. tot. mm Tot. dim. mm	Spessore isolante mm Insulating thickness mm	Press. scoppio nom. atm. Nominal burst pressure atm.	Press. esercizio nom. atm. Nominal working pressure atm.	Peso tubo rame kg/m Copper pipe weight kg/m
1/4" (6,35 x 0,80)	19,35	6,5	558,02	139,51	0,124
3/8" (9,52 x 0,80)	25,52	7	372,21	83,05	0,194
1/2" (12,7 x 0,80)	32,70	10	279,01	69,75	0,265
5/8" (15,88 x 1)	36,88	10	278,92	69,73	0,415
3/4" (19,05 x 1)	39,05	10	232,51	58,13	0,504

I dati sopra specificati si intendono a puro titolo informativo, non vincolante e soggetti ad eventuali cambiamenti. The data specified above is for information purposes only and is not binding as it is subject to possible change.

## Raccordi in rame ad inversione per split. Inversion copper fittings for split unit.

Tipo Part number	Descrizione Description	Imballo pz. Packing pcs.
RINMF14	Raccordo ad Inversione 1/4"	2
RINMF38	Raccordo ad Inversione 3/8"	2
RINMF12	Raccordo ad Inversione 1/2"	2
RINMF58	Raccordo ad Inversione 5/8"	2

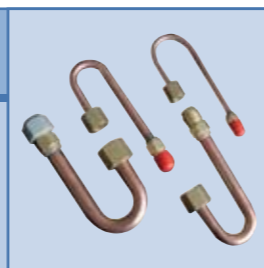

# Raccordi. Autocartellanti. Fittings. Self-outflaring.

## Bocchettoni in ottone Pipe-unions in brass

Tipo Part number	Descrizione Description	Imballo pz. Packing pcs.
BCOTN114	X NIPPLO 1/4"	50
BCOTN138	X NIPPLO 3/8"	50
BCOTN112	X NIPPLO 1/2"	50
BCOTN158	X NIPPLO 5/8"	20
BCOTN134	X NIPPLO 3/4"	20
BCOTRD143	RIDUZ. 1/4-3/8"	50
BCOTRD123	RIDUZ. 1/2-3/8"	50
BCOTRD581	RIDUZ. 5/8-1/2"	50
BCOTCC14	CIECO 1/4"	50
BCOTCC38	CIECO 3/8"	50
BCOTCC12	CIECO 1/2"	50
BCOTCC58	CIECO 5/8"	25



## Raccordi a gomito M-M e M-F Elbow fittings M-M and M-F

Tipo Part number	Descrizione Description	Imballo pz. Packing pcs.
RGOTMM14	M-M 1/4-1/4"	25
RGOTMM38	M-M 3/8-3/8"	25
RGOTMM12	M-M 1/2-1/2"	25
RGOTMM58	M-M 5/8-5/8"	10
RGOTMM34	M-M 3/4-3/4"	10
RGOTMF14	M-F 1/4-1/4"	10
RGOTMF38	M-F 3/8-3/8"	10
RGOTMF12	M-F 1/2-1/2"	10
RGOTMF58	M-F 5/8-5/8"	10
RGOTMF34	M-F 3/4-3/4"	10



## Guarnizioni in rame Copper gaskets

Tipo Part number	Descrizione Description	Imballo pz. Packing pcs.
RONDRA14	1/4"	100
RONDRA38	3/8"	100
RONDRA12	1/2"	100
RONDRA58	5/8"	100
RONDRA34	3/4"	100



## Raccordi a riduzione M-F Reducer fittings M-F

Tipo Part number	Descrizione Description	Imballo pz. Packing pcs.
RROTMF143	M-F 1/4-3/8"	10
RROTMF142	M-F 1/4-1/2"	10
RROTMF381	M-F 3/8-1/4"	10
RROTMF382	M-F 3/8-1/2"	10
RROTMF123	M-F 1/2-3/8"	10
RROTMF125	M-F 1/2-5/8"	10
RROTMF581	M-F 5/8-1/2"	10



## Raccordi lineari M-M Straight fittings M-M

Tipo Part number	Descrizione Description	Imballo pz. Packing pcs.
RLOTMM14	M-M 1/4-1/4"	25
RLOTMM38	M-M 3/8-3/8"	25
RLOTMM12	M-M 1/2-1/2"	25
RLOTMM58	M-M 5/8-5/8"	10
RLOTMM34	M-M 3/4-3/4"	10



## Raccordi a riduzione M-M Reducer fittings M-M

Tipo Part number	Descrizione Description	Imballo pz. Packing pcs.
RLOTMM143	M-M 1/4-3/8"	25
RLOTMM142	M-M 1/4-1/2"	25
RLOTMM145	M-M 1/4-5/8"	50
RLOTMM381	M-M 3/8-1/2"	25
RLOTMM385	M-M 3/8-5/8"	25
RLOTMM125	M-M 1/2-5/8"	25
RLOTMM123	M-M 1/2-3/4"	10
RLOTMM583	M-M 5/8-3/4"	10



## Autocartellanti Self-outflaring

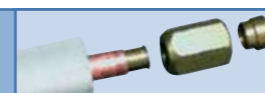

Tipo Part number	Descrizione Description	Imballo pz. Packing pcs.
ATCRT140	1/4" sp. 0,80	100
ATCRT380	3/8" sp. 0,80	100
ATCRT120	1/2" sp. 0,80	100
ATCRT141	1/4" sp. 1	100
ATCRT381	3/8" sp. 1	100
ATCRT121	1/2" sp. 1	100
ATCRT581	5/8" sp. 1	100
ATCRT341	3/4" sp. 1	50

## Ricalibratore Re-gauger



Tipo Part number	Descrizione Description	Imballo pz. Packing pcs.
ATCFO140	1/4" sp. 0,80	1
ATCFO380	3/8" sp. 0,80	1
ATCFO120	1/2" sp. 0,80	1
ATCFO141	1/4" sp. 1	1
ATCFO381	3/8" sp. 1	1
ATCFO121	1/2" sp. 1	1
ATCFO581	5/8" sp. 1	1
ATCFO341	3/4" sp. 1	1

Altrettanto per ricalibrare il diametro originale del tubo di rame dopo il taglio e permettere l'inserimento senza fatica della bussola dell'autocartellante.  
Tool to re-gauge the original diameter of the copper pipe after the cut and to allow an easy insertion of the ferrule of the self-outflaring.

# Utensili per la lavorazione dei tubi in rame. Copper pipe working tools.

## CRTEC

Cartellatrice eccentrica.  
Eccentric flaring tool.

Tipo	Imballo pz.
Part number	Packing pcs.
CRTEC	1

Cartellatrice eccentrica per tubi di rame da 1/8" - 3/16" - 1/4" - 5/16" - 3/8" - 1/2" - 5/8" - 3/4".  
Eccentric flaring tool for copper pipes sizes 1/8" - 3/16" - 1/4" - 5/16" - 3/8" - 1/2" - 5/8" - 3/4".



## UTR428

Utensile Tagliatubo.  
Pipe cutting tool.

Tipo	Imballo pz.
Part number	Packing pcs.
UTR428	1

Utensile Tagliatubo telescopico a lametta per tubi di rame da 4 a 28 mm.  
Telescopic pipe cutting tool with blade for copper pipes from 4 to 28 mm.



## UTSBR

Utensile Sbatutubo.  
Pipe bevelling tool.

Tipo	Imballo pz.
Part number	Packing pcs.
UTSBR	1

Utensile sbatutubo per tubi di rame.  
Pipe bevelling tool for copper pipes.



## ESTR145

SET Estrattore.  
Extractor kit.

Tipo	Imballo pz.
Part number	Packing pcs.
ESTR145	1

SET Estrattore per estrarre e sostituire automaticamente le valvole di tenuta senza svuotare l'impianto.  
1/4 SAE + 5/16"  
Extractor kit to extract and automatically replace the valves without emptying the system. 1/4 SAE + 5/16"



## CCVM

Cacciavite.  
Screwdriver.

Tipo	Imballo pz.
Part number	Packing pcs.
CCVM	1

Cacciavite particolare per togliere le valvole manualmente.  
Special screwdriver for manually moving valves.

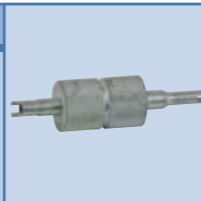

## PTT6

Pettine.  
Comb.

Tipo	Imballo pz.
Part number	Packing pcs.
PTT6	1

Pettine per pareggiare le alette radiatori di raffreddamento  
6 versioni di distanza.  
Comb to balance the cooling fins 6 sizes.

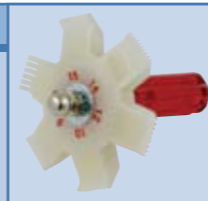

## CRVTL

Curvatrice a leva.  
Level bender.

Tipo	Imballo pz.
Part number	Packing pcs.
CRVTL	1

Curvatrice a leva per piegare a 180° tubi rame 1/4 - 5/16 - 3/8.  
Level bender to bend at 180° copper pipes sizes 1/4 - 5/16 - 3/8.



## CRVTC

Curvatrice a cricco.  
Jack bender.

Tipo	Imballo pz.
Part number	Packing pcs.
CRVTC	1

Curvatrice a cricco per piegare tubi rame da 3/8 - 1/2 - 5/8 - 3/4 - 7/8.  
Jack bender to bend copper pipes sizes 3/8 - 1/2 - 5/8 - 3/4 - 7/8.



## CHDINE

SET Chiavi Dinamometriche.  
Dynamometrical keys set.

Tipo	Imballo pz.
Part number	Packing pcs.
CHDINE	1

SET Chiavi Dinamometriche per 17 - 22 - 24 - 26 - 27 - 29.  
Dynamometrical keys set for 17 - 22 - 24 - 26 - 27 - 29.



## CHDINPB

SET Chiavi Dinamometriche Professionali.  
Professional dynamometrical keys set.

Tipo	Imballo pz.
Part number	Packing pcs.
CHDINPB	1

SET Chiavi Dinamometriche Professionali con adattatore per chiave a bussola da 17 - 22 - 24 - 26 - 27 - 29.  
Professional dynamometrical keys set with adapter for socket spanner 17 - 22 - 24 - 26 - 27 - 29.



## TERLIN

Termometro Laser-infrarosso.  
Laser-infrared thermometer.

Tipo	Imballo pz.
Part number	Packing pcs.
TERLIN	1

Termometro Laser-infrarosso - precisione  $\pm 2^{\circ}\text{C}$  - Scala da  $-20^{\circ}\text{C}$  a  $+420^{\circ}\text{C}$  - Batteria di alimentazione 9 V  
Risposta immediata - D/S = 8:1 Autospegnimento dopo 4" - Dimensioni 44x40x170 mm - Peso 170 g.  
Laser-infrared thermometer - precision  $\pm 2^{\circ}\text{C}$  - From  $-20^{\circ}\text{C}$  to  $+420^{\circ}\text{C}$  - Powered by 9 V battery-Immediate reply - D/S = 8:1 Autopower shutoff after 4" - Dimensions 44x40x170 mm - Weight 170 g.



## TERDIG

Termometro Digitale.  
Digital thermometer.

Tipo	Imballo pz.
Part number	Packing pcs.
TERDIG	1

Termometro Digitale - Scala temperatura da  $-40^{\circ}\text{C}$  a  $+200^{\circ}\text{C}$   
Sonda 7 cm - funzione richiamo min/max - Autospegnimento.  
Digital thermometer - From  $-40^{\circ}\text{C}$  to  $+200^{\circ}\text{C}$   
Probe 7 cm - min/max warning function - Auto power shutoff.

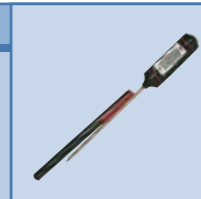

## LTK1OPV

Lattina olio.  
Lube oil bottle.

Tipo	Imballo pz.
Part number	Packing pcs.
LTK1OPV	10

Lattina 1l - olio lubrificante per Pompe Vuoto.  
1 ltr bottle - lube oil for vacuum pump.



## Gas. Gas.

## REF1R407

Gas Refrigerante R407.  
Cooling gas R407.

Tipo	Imballo pz.
Part number	Packing pcs.
REF1R407	6

Bomboletta Gas Refrigerante R407.  
Bottle of cooling gas R407.



## REF1R410A

Gas Refrigerante R410A.  
Cooling gas R410A.

Tipo	Imballo pz.
Part number	Packing pcs.
REF1R410A	6

Bomboletta Gas Refrigerante R410A.  
Bottle of cooling gas R410A.



## RILF1

Rilevatore fughe.  
Gas-escape marker.

Tipo	Imballo pz.
Part number	Packing pcs.
RILF1	24

Rilevatore fughe per impianti frigoriferi, 400ml.  
Gas-escape marker for cooling systems, 400 ml.



## SYIG1

Spray Igienizzante Sanificante.  
Sanitizing-hygienizing spray.

Tipo	Imballo pz.
Part number	Packing pcs.
SYIG1	12

Spray igienizzante per climatizzatori, 400ml.  
Sanitizing-hygienizing spray for aircon systems, 400 ml.



# Strumenti ed accessori per il controllo dei gas. Tools and accessories for gas control.

# Manometri e tubazioni flessibili. Manometers and hoses.

## PMB

Pompa per vuoto Bistadio.  
Bistadio vacuum pump.



Tipo	Lt.	Imballo pz.
Part number	Lt.	Packing pcs.
PMB46BAS	46	1
PMB72BAS	72	1

Pompa per vuoto Bistadio con elettrovalvola e vacuometro  
Vacuum 0,02 mbar - Alimentazione 220 V.  
Bistadio vacuum pump with electro-valve and vacuum-meter  
Vacuum 0,02 b-Feed 220V.

## PMRERI

Sistema di recupero e riciclo.  
Recycling system.



Tipo	Imballo pz.
Part number	Packing pcs.
PMRERI	1

Sistema di recupero e riciclo dei gas refrigeranti.  
Adatta per R12 - R22 - R404 - R407 - R502 - R507 - R134A - R410A.  
Cap. recupero = kg 20/ora - Autosvuotamento automatico.  
Cooling gases recycling system.  
Suitable for R12 - R22 - R404 - R407 - R502 - R507 - R134A - R410A.  
Recycling capacity=kg 20/hour - Auto self-emptying.

## BEL55

Bilancia Elettronica.  
Electronic scales.



Tipo	Imballo pz.
Part number	Packing pcs.
BEL55	1

Bilancia Elettronica a batteria per la quantificazione precisa del refrigerante usato o recuperato.  
Portata kg 55 - Grado precisione ± 2 g.  
Peso kg 27 - Dimensione 22,5x22,5 cm.  
Battery-powered electronic scales for a precise quantification of used and recycled coolant.  
Capacity kg 55 - Precision degree ± 2 g.  
Weight kg 27 - Dimension 22,5x22,5 cm.

## BEL5

Bilancia Elettronica.  
Electronic scales.



Tipo	Imballo pz.
Part number	Packing pcs.
BEL5	1

Bilancia Elettronica a batteria - Portata max 5 kg - Precisione ± 1 g  
Dimensioni 11x32x43 cm + Supporto per bombola.  
Battery-powered electronic scales.  
- Capacity max 5 kg - Precision ± 1 g  
Dimensions 11x32x43 cm + bottle support.

## CRFU1SE

KIT Cercafughe Elettronico.  
Electronic centrifuge kit.



Tipo	Imballo pz.
Part number	Packing pcs.
CRFU1SE	1

KIT Cercafughe Elettronico con 1 sensore di ricambio - Durata sensore = 20 ore.  
Durata batterie = 30 ore - Display a 7 led - Riscaldamento = 2 sec.  
7 livelli di sensibilità - Garanzia 2 anni.  
Electronic centrifuge kit with 1 spare sensor - Sensor life=20 hours.  
Battery runtime=30 hours - 7led display - Heating=2 sec.  
7 sensitivity levels - Warranty=2 years.

## LVIMPAZ

KIT lavaggio impianti.  
System washing kit.



Tipo	Imballo pz.
Part number	Packing pcs.
LVIMPAZ	1

KIT lavaggio impianti - Pressione 200 bar - Riduttore azoto.  
Cartuccia 950 cc azoto a 110 bar in comoda valigetta.  
System washing kit. Pressure 200 bar - Nitrogen reducer.  
950 cc nitrogen cartridge at 110 bar in handy case.

## ARTICON TROLLEY

KIT completo per "VUOTO e CARICO" dei GAS.  
Complete kit for gas suction and refill.

Tipo	Descrizione	Imballo pz.
Part number	Description	Packing pcs.
TROLLCP	TROLLEY ARTICON LINEA CONDIZIONAMENTO	1
PMB46BAS	POMPA X VUOTO BISTADIO C/ELETTROVALVOLA	1
MONO41480	GRUPPO MANOMETRICO 4 VIE GAS R410	1
MONO22480	GRUPPO MANOM. 4 VIE GAS R22/R404/R407/R134A	1
BEL5	BILANCIA ELETTRONICA A BATTERIA MAX 5KG	1
FLEX45R14	KIT 3 TUBI FLEX A 45° CON RUBINETTO	1
REF1R410A	GAS REFRIGERANTE R410A	1
RILF1	RILEVATORE FUGHE PER IMPIANTI	1
ROLMF145	RACCORDO A "L" (R410) SAE 1/4MX5/16F	1
CRTEC	CARTELLATRICE ECCENTRICA X TUBI RAME	1
UTR428	UTENSILE TAGLIATUBO TELESOPICO A	1
UTSBR	UTENSILE SBVATUBO PER TUBI DI RAME	1
RINMF14	RACCAD INVERSIONE X SPLIT M-F 1/4-1/4"	2
RINMF38	RACCAD INVERSIONE X SPLIT M-F 3/8-3/8"	2
BCOTN14	BOCCH.OTTONE X NIPPLO 1/4"	20
BCOTN38	BOCCH.OTTONE X NIPPLO 3/8"	10
RONDRA14	GUAR.RAME X RACCORDI 1/4"	20
RONDRA38	GUAR.RAME X RACCORDI 3/8"	10



Tipo	Imballo pz.
Part number	Packing pcs.
ARTICON TROLLEY09	1

## MONO41480

Gruppo manometrico Ø 80.  
Manometer group Ø 80.

Tipo	Imballo pz.
Part number	Packing pcs.
MONO41480	1

Gruppo manometrico Ø 80 con monoblocco a 4 vie per gas R410.  
Manometer group Ø 80 with 4-way monoblock for gas R410.

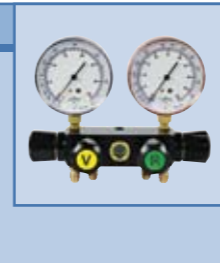

## MONO22480

Gruppo manometrico Ø 80.  
Manometer group Ø 80.

Tipo	Imballo pz.
Part number	Packing pcs.
MONO22480	1

Gruppo manometrico Ø 80 con monoblocco a 4 vie per gas.  
R22 - R404 - R407 - R134A.  
Manometer group Ø 80 with 4-way monoblock for gas R22 - R404 - R407 - R134A.

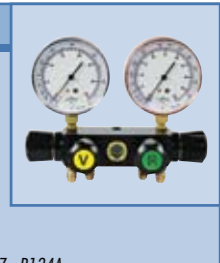

## VCU63

Vacuometro Ø 63.  
Vacuometer Ø 63.

Tipo	Imballo pz.
Part number	Packing pcs.
VCU63	1

Vacuometro Ø 63 - attacco posteriore 1/8 NPT.  
Vacuometer Ø 63 - back fitting 1/8 NPT.

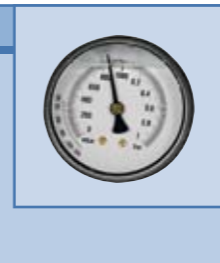

## MBP80

Manometro Bassa Pressione.  
Low pressure manometer.

Tipo	Imballo pz.
Part number	Packing pcs.
MBP80	1

Manometro Bassa Pressione Ø 80 - attacco radiale 1/8 NPT.  
Low pressure manometer Ø 80 - radial fitting 1/8 NPT.

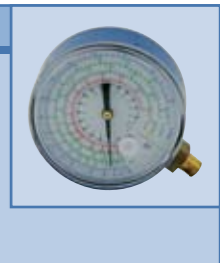

## MAP80

Manometro Alta Pressione.  
High pressure manometer.

Tipo	Imballo pz.
Part number	Packing pcs.
MAP80	1

Manometro Alta Pressione Ø 80 - attacco radiale 1/8 NPT.  
High pressure manometer Ø 80 - radial fitting 1/8 NPT.

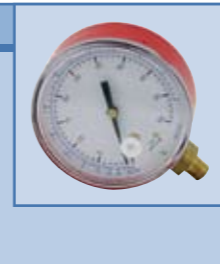

## FLET45H14

Tubo Flex Terminale Alta Pressione.  
High pressure terminal hose.

Tipo	Imballo pz.
Part number	Packing pcs.
FLET45H14	1

Tubo Flex Terminale Alta Pressione (H) a 45° - Attacco filetto 1/4" L = 150 mm Conf. SAE J2196  
Temperatura esercizio -30°C +125°C - Pressione lavoro = 60 bar - Pressione scoppio = 240 bar.  
High pressure terminal hose (H) at 45° - Fitting thread 1/4" - L = 150 mm each. Conforming. SAE J2196  
Working temp. -30°C +125°C - Working pressure = 60 bar - Burst pressure = 240 bar.



## FLEX45R14

Kit 3 Tubi Flex.  
3 hoses kit.

Tipo	Imballo pz.
Part number	Packing pcs.
FLEX45R14	1

Kit 3 Tubi Flex a 45° con rubinetto - Attacco filetto 1/4" - L = 1.500 mm cad. Conf. SAE J2196  
Temperatura esercizio -30°C +125°C - Pressione lavoro = 60 bar - Pressione scoppio = 240 bar.  
Kit of 3 hoses at 45° with tap - Fitting thread 1/4" - L = 1.500 mm each. Conforming. SAE J2196  
Working temp. -30°C +125°C - Working pressure = 60 bar - Burst pressure = 240 bar.



## ROLMF145

Raccordo a "L".  
"L" fitting.

Tipo	Imballo pz.
Part number	Packing pcs.
ROLMF145	1

Raccordo a "L" (R410) SAE 1/4M x 5/16F per FLEX45R14.  
"L" fitting (R410) SAE 1/4M x 5/16F for FLEX45R14.



## FLET45L14

Tubo Flex Terminale Bassa Pressione.  
Low pressure terminal hose.

Tipo	Imballo pz.
Part number	Packing pcs.
FLET45L14	1

Tubo Flex Terminale Bassa Pressione (L) a 45° - Attacco filetto 1/4" L = 150 mm.  
Conf. SAE J2196 - Temp. esercizio -30°C +125°C Pressione lavoro = 60 bar - Pressione scoppio = 240 bar.  
Low pressure terminal hose (L) at 45° - Fitting thread 1/4" - L = 150 mm each. Conforming. SAE J2196  
Working temp. -30°C +125°C - Working pressure = 60 bar - Burst pressure = 240 bar.

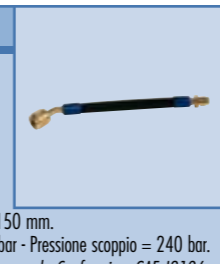

## CPRG20

Guarnizione ricambio in gomma per tubi flex.  
Spare gasket for hoses.

Tipo	Imballo pz.
Part number	Packing pcs.
CPRG20	50

