



DOMINIO

Sistema modulare di canalizzazione portacavi.
Modular trunking system.



pagina / page

2.6.4

Accessori.
Accessories.



pagina / page

2.6.11

Dati tecnici.
Technical data.



pagina / page

2.6.12



Il sistema di fissaggio alla mensola permette la naturale dilatazione termica del canale. The system of fixing to the bracket allows the natural thermal expansion of the trunkings.

Canali modulari di sezione alveolare rinforzata e accessori che danno luogo a configurazioni illimitate, adattabili ad impianti "su misura" predisposti per interventi di modifica nel tempo. Modular trunkings with strengthened cell-like section and special accessories integrate and give rise to unlimited configurations adaptable to customised systems arranged for easy later changes.



Guide per incastrare coperchi e accessori. **Groovers** for joining covers and accessories.

Pareti laterali per inserimento a scatto. **Lateral walls** for snapping on accessories.

Fondo alveolare per irrobustire il canale, dissipare il calore. **Cell-like bottom** to strengthen the trunkings and to dissipate the heat.

Guide sul fondo per l'ancoraggio degli accessori. **Rail on the bottom** for the fastening of the accessories.

Guide per l'ancoraggio dei traversini. **Fastening** of cross arm.

Guide laterali per l'inserimento degli accessori. **Lateral grooves** for inserting the accessories.

Guide	Sezione fondo	Tipo	Dimensioni BxH mm	Colore	Imballo m	S.G. mm ²	Lung. barre m	Cartone peso Kg
Rails	Section of the bottom	Part number	Duct Size BxH mm	Colour	Standard Carton m	G.S. mm ²	Length m	Carton Weight Kg
▲		DMC10	100x62,5		15	5200	2,50	18,5
▲		DMC15	150x62,5		10	7900	2,50	15,3
▲		DMC20	200x62,5		10	10600	2,50	18,7

▲ Canali con guide sul fondo. Trunkings with rails on the bottom.

Canale modulare per installazione, portacavi e portautenze. Coperchio smontabile con attrezzo. Materiale: PVC Rigido Autoestinguente Classe 1 (UL94-VO). Lunghezza: 2,50 metri

Modular installation trunking. Cover removable with tool. Self-extinguishing rigid PVC Class 1 (UL94-VO). Length: 2,50 meters



A Norme CEI 23-32 SF PCF AN50

IP 40 - GWT = T850°

Codifica per l'ordine dei canali
Functional part numbering system

DMC10

Tipo
Type

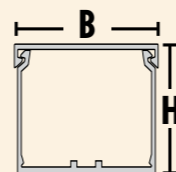

COLORI COLOURS = Grigio chiaro / Light Grey Type 7035

- Colore standard Grigio chiaro Type 7035.
- Standard colour light grey Type 7035.



Per smontare e montare il coperchio del canale, premere la parte centrale del coperchio stesso e far leva lateralmente con un cacciavite. To dismantle and fit the trunking cover, press down on the centre of the cover itself and lever with a screwdriver at the side.

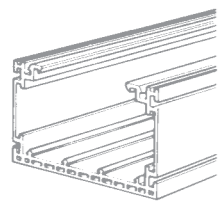

IP 40 - GWT = T850°

Guide	Tipo	Colore	BxH mm
Rails	Part number	Colour	BxH mm

▲	DMC10	□	100x62,5
▲	DMC15	□	150x62,5
▲	DMC20	□	200x62,5

DMCO

Coperchio per canale.
Lunghezza: 2,5 m
Cover for trunking.
Length: 2,5 m

Tipo	Colore	Imballo m
Part number	Colour	Packing m

DMC010	□	15
DMC015	□	10
DMC020	□	10

DMU

Attrezzo per forare le pareti laterali del canale DMC per l'aggancio di alcuni accessori.
Boring tool for the side wall (fixing to DM50 - DM60 - DM270 - DM55 - DMTR).

Tipo	Colore	Imballo pz.
Part number	Colour	Packing pcs.

DMU	■	1
DMU	■	1
DMU	■	1

DMA

Profilo accoppiamento canali.
Lunghezza: 1,25 m
Trunking matching profile.
Length: 1,25 m

Tipo	Colore	Imballo m
Part number	Colour	Packing m

DMA	□	50
DMA	□	50
DMA	□	50

DMT

Traversino di contenimento cavi e separatore.
Si utilizza anche con LDS50.
Cross arm for cables and separator.
Use with LDS50 too.
Colore/Colour: Nero/Black

Tipo	Colore	Imballo pz.
Part number	Colour	Packing pcs.

DMT10	■	200 (4x50)
DMT15	■	200 (4x50)
DMT20	■	200 (4x50)

LDS50

Separatore cavi. Lunghezza: 1 m
Cable separator. Length: 1 m

Tipo	Colore	Imballo m
Part number	Colour	Packing m

LDS50	□	50
LDS50	□	50
LDS50	□	50

DMF

Portafascette.
Cable-tie holder.
Colore/Colour: Nero/Black

Tipo	Colore	Imballo pz.
Part number	Colour	Packing pcs.

DMF	■	100 (2x50)
DMF	■	100 (2x50)
DMF	■	100 (2x50)

DM050

Giunto tra due canali.
Forare le pareti del canale con DMU.
Coupling between two trunkings.
Drill the walls of the trunking with a DMU.

Tipo	Colore	Imballo pz.
Part number	Colour	Packing pcs.

DM050	□	12 kit
DM050	□	12 kit
DM050	□	12 kit

DM060

Giunto snodato in abbinamento con DMSN.
Forare le pareti del canale con DMU.
Articulated coupling to be supplied with DMSN.
Drill the walls of the trunking with a DMU.

Tipo	Colore	Imballo pz.
Part number	Colour	Packing pcs.

DM060	□	10 kit
DM060	□	10 kit
DM060	□	10 kit

DM060P

Giunto snodato in abbinamento con DMSN per discesa a 90°.
Forare le pareti del canale con DMU.
Articulated coupling to be supplied with DMS for 90° lowering. Drill the walls of the trunking with a DMU.

Tipo	Colore	Imballo pz.
Part number	Colour	Packing pcs.

DM060P	□	4 kit
DM060P	□	4 kit
DM060P	□	4 kit

DMSN 30

Coprigiunto a 30° per DM060.
30 degree coupling cover for DM060.

Tipo	Colore	Imballo pz.
Part number	Colour	Packing pcs.

DMSN130	□	10
DMSN230	□	10
DMSN330	□	10

DMSN 45

Coprigiunto a 45° per DM060.
45 degree coupling cover for DM060.

Tipo	Colore	Imballo pz.
Part number	Colour	Packing pcs.

DMSN145	□	10
DMSN245	□	10
DMSN345	□	10

DMSN 60

Coprigiunto a 60° per DM060.
60 degree coupling cover for DM060.

Tipo	Colore	Imballo pz.
Part number	Colour	Packing pcs.

DMSN160	□	10
DMSN260	□	10
DMSN360	□	10

DMSN 90

Coprigiunto a 90° per DM060.
90 degree coupling cover for DM060.

Tipo	Colore	Imballo pz.
Part number	Colour	Packing pcs.

DMSN190	□	10
DMSN290	□	10
DMSN390	□	10

DM300

Mensola a parete con tappo chiusura.
Wall bracket with cap.

Tipo	Colore	Imballo pz.
Part number	Colour	Packing pcs.

DM300	□	9
DM300	□	9
DM300	□	9

DM301

Prolunga per mensola DM300 completa di perno fissaggio DM322.
Extension for DM300 bracket complete with fixing pin DM322.

Tipo	Colore	Imballo pz.
Part number	Colour	Packing pcs.

DM301	□	9
DM301	□	9
DM301	□	9

DM303

Graffa per fissaggio canale su DM300-DM301.
Fastening clip for trunking fixing into DM300-DM301.

Tipo	Colore	Imballo pz.
Part number	Colour	Packing pcs.

DM303	□	50
DM303	□	50
DM303	□	50

DM304

Graffa per sospensione canale in orizzontale su DM300-DM301.
Horizontal trunking suspension clip into DM300-DM301.

Tipo	Colore	Imballo pz.
Part number	Colour	Packing pcs.

DM304	□	50
DM304	□	50
DM304	□	50

DM305

Graffa per sospensione canale in verticale su DM300-DM301.
Vertical trunking suspension clip into DM300-DM301.

Tipo	Colore	Imballo pz.
Part number	Colour	Packing pcs.

DM305	□	20
DM305	□	20
DM305	□	20

DMD

Distanziatore per canale a parete completo di DM303.
Wall ducting spacer complete with DM303.

Tipo	Colore	Imballo pz.
Part number	Colour	Packing pcs.

DMD10	□	18
DMD15	□	12
DMD20	□	9

DMSO

Supporto per canale sospeso a soffitto.
Support for ceiling suspended trunking.

Tipo	Colore	Imballo pz.
Part number	Colour	Packing pcs.

DMSO10	□	20
DMSO15	□	15
DMSO20	□	15

DM321

Canale Omega portamensola per applicazione a soffitto o parete (DM300-DM320). Lunghezza: 2 m
Bracket-holding Omega trunking for ceiling or wall mounting (DM300-DM320). Length: 2 m

Tipo	Colore	Imballo m
Part number	Colour	Packing m

DM321	□	12
DM321	□	12
DM321	□	12

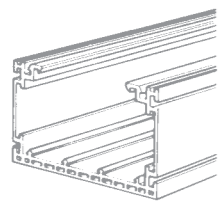

IP 40 - GWT = T850°

Guide	Tipo	Colore	BxH mm
Rails	Part number	Colour	BxH mm

▲	DMC10	□	100x62,5
▲	DMC15	□	150x62,5
▲	DMC20	□	200x62,5

Guide	Tipo	Colore	BxH mm
Rails	Part number	Colour	BxH mm

▲	DMC10	□	100x62,5
▲	DMC15	□	150x62,5
▲	DMC20	□	200x62,5

Guide	Tipo	Colore	BxH mm
Rails	Part number	Colour	BxH mm

▲	DMC10	□	100x62,5
▲	DMC15	□	150x62,5
▲	DMC20	□	200x62,5

DM320

Supporto a soffitto per canale Omega DM321.
I = Inox - F = Ferro zincato.
Ceiling support for DM321 Omega trunking.
Material: I = Inox - F = Zinc iron

Tipo	Colore	Imballo pz.
Part number	Colour	Packing pcs.

DM320I	DM320F	■	9
DM320I	DM320F	■	9
DM320I	DM320F	■	9

DMAE

Angolo esterno 90° completo di coperchio e separatori.
90° outer bend complete with cover and separators.

Tipo	Colore	Imballo pz.
Part number	Colour	Packing pcs.

DMAE10	□	12
DMAE15	□	5
DMAE20	□	5

DM090

Placca portamostrine. Permette il montaggio della mostrina DM075 (con distanziatore) e DM072 - DM073 - DM0736.
Panel point packets. Can take DM075 panel (with spacer) and DM072 - DM073 - DM0736.

Tipo	Colore	Imballo pz.
Part number	Colour	Packing pcs.

DM0901	□	15
DM0902	□	15
DM0903	□	15

DM322

Perno fissaggio per mensola DM300 a canale Omega DM321.
Pin for fixing DM300 bracket into DM321.
Omega trunking.
Colore/Colour: Nero/Black

Tipo	Colore	Imballo pz.
Part number	Colour	Packing pcs.

DM322	■	20
DM322	■	20
DM322	■	20

DMTR

Tappo terminale e riduzione canali.
Forare le pareti del canale con DMU.
Trunking end cap and reduction.
Drill the walls of the trunking with a DMU.

Tipo	Colore	Imballo pz.
Part number	Colour	Packing pcs.

DMTR10	□	20
DMTR15	□	20
DMTR20	□	20

DM072

Mostrina per il montaggio di 2 prese SCHUKO.
Plate for mounting of 2 SCHUKO sockets.

Tipo	Colore	Imballo pz.	Mostrina
Part number	Colour	Packing pcs.	Panel

DM072AV	C	20	AVE - Blanc/Noir
DM072GW	C	20	GEWISS - Serie 20
DM072TT	C	20	TICINO - TT
DM072VIP	C	20	VIMAR - Plana

DM323

Staffetta fissaggio canale - Omega/soffitto.
I = Inox - F = Ferro zincato.
Clip for fixing the Omega trunking to the ceiling.
I = Inox - F = Zinc iron

Tipo	Colore	Imballo pz.
Part number	Colour	Packing pcs.

DM323I	DM323F	■	18
DM323I	DM323F	■	18
DM323I	DM323F	■	18

DMCG

Coprigiunto coperchio.
Coupling cover for covers.

Tipo	Colore	Imballo pz.
Part number	Colour	Packing pcs.

DMCG10	□	25
DMCG15	□	25
DMCG20	□	25

DM270

Giunzione a "T".
Forare le pareti del canale con DMU.
"T" coupling.
Drill the walls of the trunking with a DMU.

Tipo	Colore	Imballo pz.
Part number	Colour	Packing pcs.

DM270	□	6 kit
DM270	□	6 kit
DM270	□	6 kit

LDPUVA

Supporto per utenze con interasse 108 mm.
Support for socket points with centres of 108 mm.
Colore/Colour: Nero/Black

Tipo	Colore	Imballo pz.
Part number	Colour	Packing pcs.

LPUVA	■	15
LPUVA	■	15
LPUVA	■	15

DM073

Mostrina per utenze con interasse 83,5 (3 moduli).
Plate for sockets with centres of 83,5 mm (3 modules).

Tipo	Colore	Imballo pz.
Part number	Colour	Packing pcs.

DM073	GC	20
DM073	GC	20
DM073	GC	20

DM055

Giunto canale con curva DMCP.
Forare le pareti del canale con DMU.
Trunking coupling with DMCP bend.
Drill the walls of the trunking with a DMU.

Tipo	Colore	Imballo pz.
Part number	Colour	Packing pcs.

DM055	□	12 kit
DM055	□	12 kit
DM055	□	12 kit

DMPU

Coperchio di protezione per apparecchiature con interasse 108 mm. Si usa con il supporto LDPUVA.
Protection covers for equipments with centres of 108 mm. Use with LDPUVA support.

Tipo	Colore	Imballo pz.
Part number	Colour	Packing pcs.

DMPU10	□	10
DMPU15	□	10
DMPU20	□	10

DM0736

Mostrina per utenze con interasse 55/60 mm (2 moduli).
Plate for sockets with centres distance of 55/60 mm (2 modules).

Tipo	Colore	Imballo pz.
Part number	Colour	Packing pcs.

DM0736	GC	20
DM0736	GC	20
DM0736	GC	20

DMCP

Curva piana 45° completa di separatori e coperchio.
45° flat bend complete with separators and covers.

Tipo	Colore	Imballo pz.
Part number	Colour	Packing pcs.

DMCP10	□	16
DMCP15	□	12
DMCP20	□	10

DM100

Scatola portautenze per apparecchi con interasse 60 e 83,5 mm interne ai canali.
Socket point to be installed inside trunking with centres 60 and 83,5 mm
Colore/Colour: Nero/Black

Tipo	Colore	Imballo pz.
Part number	Colour	Packing pcs.

DM100	■	15
DM100	■	15
DM100	■	15

DM075

Mostrina per magnetotermici orizzontali (max.5).
Plate for horizontal magnetothermic devices (max 5).

Tipo	Colore	Imballo pz.
Part number	Colour	Packing pcs.

DM075	GC	10
DM075	GC	10

DMAI

Angolo interno 90° completo di coperchio e separatori.
90° inner internal bend complete with cover and separators.

Tipo	Colore	Imballo pz.
Part number	Colour	Packing pcs.

DMAI10	□	10
DMAI15	□	10
DMAI20	□	10

DM105

Portapparecchi modulari 17,5 (max 5) e morsetti. Si usa con DM090.
Modular switches (17,5 - maximum n° 5) and clamps holder. Use with DM090.
Colore/Colour: Nero/Black

Tipo	Colore	Imballo pz.
Part number	Colour	Packing pcs.

DM105	■	15
DM105	■	15

DM180

Scatola di derivazione e portautenze.
Junction box and socket point.

Tipo	Colore	Imballo pz.
Part number	Colour	Packing pcs.

DM180	GC	12
-------	----	----

▲ Canali con guide sul fondo. Trunkings with rails on the bottom.

■ Fornibile a richiesta e per quantità da concordare. Available on request and for quantities to be agreed.

□ / GC = Grigio Chiaro / Light Grey Type 7035 ■ = Nero / Black Type 9017

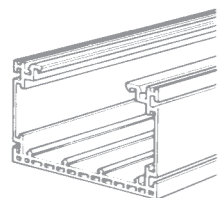

IP 40 - GWT = T850°

Guide	Tipo	Colore	BxH mm
Rails	Part number	Colour	BxH mm

▲	DMC10	□	100x62,5
▲	DMC15	□	150x62,5
▲	DMC20	□	200x62,5

DM280

Scatola di derivazione e portautenze doppia.
Double junction box and socket point.

Tipo	Colore	Imballo pz.
Part number	Colour	Packing pcs.

DM280	GC	6
DM280	GC	6
DM280	GC	6

DM281

Adattatore per canali Dominio alle scatole DM280 e DM180.
Adaptor for Dominio trunking to DM280-DM180 boxes.

Tipo	Colore	Imballo pz.
Part number	Colour	Packing pcs.

DM2811	□	10
DM2812	□	10
DM2813	□	10

FMC

Fermacavo universale per canali Tipo G, LDC e Dominio.
Cable fastener for Tipo G, LDC and Dominio trunkings.
Colore/Colour: Nero/Black

Tipo	Colore	Imballo pz.
Part number	Colour	Packing pcs.

FMC	■	40 (4x10)
FMC	■	40 (4x10)
FMC	■	40 (4x10)

TS

Tassello ad espansione per il fissaggio dei canali a parete, 2-3 per m. Completamente isolato, con testa vite a scomparsa.
Wall plug for wall-mounting of the ducting (2-3 per meter). Completely isolated, with a countersunk screw. Ø 6 mm
Colore/Colour: Nero/Black

Tipo	Colore	Imballo pz.
Part number	Colour	Packing pcs.

TS	■	100
----	---	-----

RIV

Vite e dado in nylon. Ø 6 e 8 mm
Nylon screw and nut. Ø 6 and 8 mm
Colore/Colour: Bianco/White

Tipo	Colore	Imballo pz.
Part number	Colour	Packing pcs.

RIV6	□	1000 (10x100)
RIV8	□	500 (5x100)

LDG1

Giunto collegamento fondo canali e scatole DM180-DM280 in sospensione. Utilizza viti autofilettanti (nella confezione).
Joint for connecting the base of the trunkings and DM180-DM280 boxes in a suspended installation. Use self-tapping screws (in the packing).
Colore/Colour: Nero/Black

Tipo	Colore	Imballo pz.
Part number	Colour	Packing pcs.

LDG1	■	25 (5x5)
------	---	----------

LDG1

Per l'utilizzo delle scatole DM180 e DM280 con applicazione sospesa usare l'accessorio LDG1 fissandolo alla base del canale e della scatola.
In order to use DM180 and DM280 boxes in a suspended installation, please use LDG1 accessory by fastening it at the base of trunking and box.



▲ Canali con guide sul fondo. Trunkings with rails on the bottom.

□ GC = Grigio Chiaro / Light Grey Type 7035 ■ = Nero / Black Type 9017

Accessori. Accessories.

DM180

Tipo	Colore	Dimensioni	Imballo pz.
Part number	Colour	Dimensions	Packing pcs.

DM180	GC	125x125x83	12
-------	----	------------	----

Scatola di derivazione e portautenze.
Junction box and socket point.



2

DM280

Tipo	Colore	Dimensioni	Imballo pz.
Part number	Colour	Dimensions	Packing pcs.

DM280	GC	250x125x83	6
-------	----	------------	---

Scatola di derivazione e portautenze doppia.
Double junction box and socket point.



DM281

Tipo	Colore	Dimensioni	Imballo pz.
Part number	Colour	Dimensions	Packing pcs.

DM2811*	□	100x62,5	10
DM2812	□	150x62,5	10
DM2813	□	200x62,5	10

Adattatore.
Per derivare dalla scatola DM280 canali DMC (Dominio).
*Anche per scatola DM180

Adaptor
For junction between DM280 box and DMC (Dominio) trunkings.
*Also for DM180 box

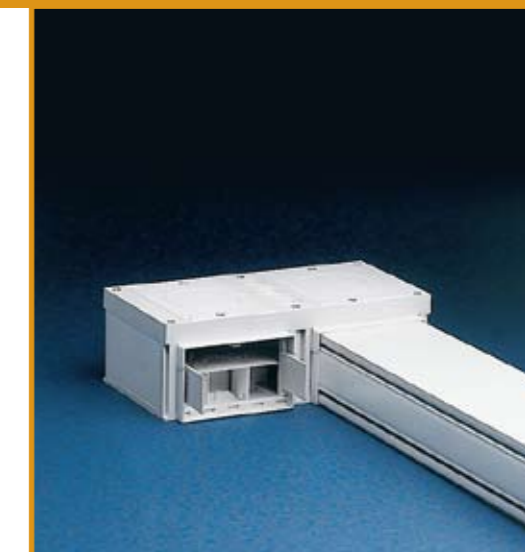

□ GC = Grigio Chiaro / Light Grey Type 7035

DMC

Dimensioni e disposizione guide sul fondo.
Sizes and layout of the rails on the bottom.

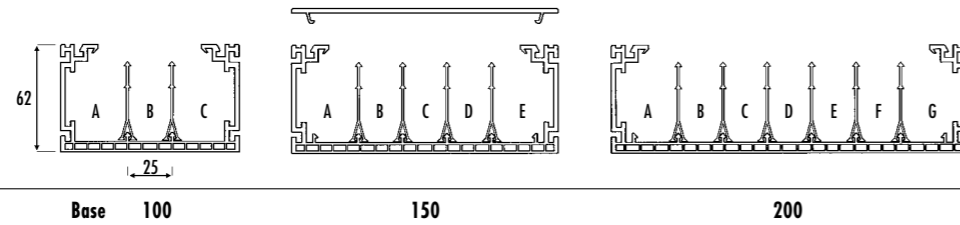

Utilizzo dei separatori LDS50 all'interno dei canali DMC. Sezioni degli scomparti in mm².
Use of the LDS50 separators inside the DMC trunkings. Compartments section in mm².

Dimensioni	N° scomparti LDS50	Sezione / Section mm ²							
Dimensions	N° compartments LDS50	A	B	C	D	E	F	G	
100x62,5	3	1925	1350	1925	-	-	-	-	-
150x62,5	5	1925	1350	1350	1350	1925	-	-	-
200x62,5	7	1925	1350	1350	1350	1350	1350	1350	1925

Ancoraggio trasversini:
Fastening of cross arm:

DMT

Guide sul fondo per l'ancoraggio di:
Rails on the bottom for the fastening of:

LDS50 - DMF - DM270 (Accessorio non promiss. cavi/Cable non-cross accessory)
LDPUVA - DM105 - DM100

Pareti laterali per inserimento a scatto:
Lateral wall for snap-in mounting:

DM050 - DM060 - DM270 - DM055
DMTR - DM281

Guide per incastro coperchi e accessori:
Rail for joint covers and accessories:

DMCO - DMCG - DMPU - DM090

Guide per l'inserimento degli accessori:
Rail for inserting the accessories:

DMA - DM300 - DM304 - DM305
DM303 - DMD - DMSO

Fondo alveolare per irrobustire il canale, dissipare il calore e inserire i pettini per:
Cell-like bottom to strengthen the trunkings, to dissipate the heat and to insert the teeth for:

DM050 - DM270 - DM055

DMA

Accessorio che permette l'accoppiamento tra canali.
To place trunkings side by side.

Combinazioni possibili utilizzando l'accessorio DMA
Possible combinations with DMA accessory

Due canali / Two trunkings			
A	+	B	= C
100	+	100	= 200
100	+	150	= 250
150	+	150	= 300
150	+	200	= 350
200	+	200	= 400

Tre canali / Three trunkings					
A	+	B	+	C	= D
100	+	100	+	100	= 300
100	+	100	+	150	= 350
100	+	150	+	150	= 400
150	+	150	+	150	= 450
150	+	200	+	200	= 550
200	+	200	+	200	= 600

Accostare 2 o più canali ed inserire il profilo DMA nelle sedi predisposte.
N.B. Si consiglia di inserire i profili per tutta la lunghezza del canale.
Place two or more trunkings side by side and insert DMA in their grooves.
P.N. We recommend to insert it all along the whole length of the trunking.

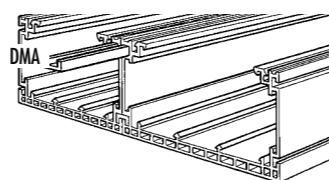
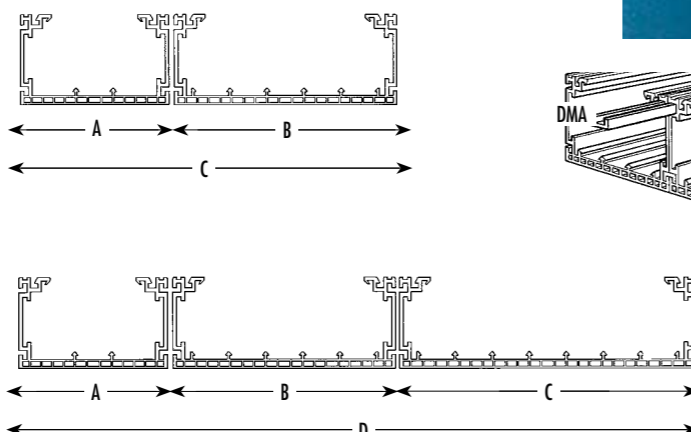

Contenenza cavi e carichi / Wire fill capacity and loads

Descrizione / Description				DMC10	DMC15	DMC20
Dimensioni ester. canale con coperchio mm Outer size of trunking with cover mm				100 x 62,5	150x62,5	200x62,5
Sezione geometrica mm ² Geometric section mm ²				5.200	7.900	10.600
Peso canale dal-m Trunking weight dal-m				1,60	2,00	2,350

Tipo cavo N. conduttori x sez. nominale Type of cable N. ducts x rated section	Ø est. cavo mm. Outer Ø of cable mm	Sez. necessaria per un cavo mm ² Necessary section x 1 cable mm ²	Peso cavo Weight cable dal-m.	Numero cavi contenuti nei canali con coeff. di riempim. 100% Number of cable contained within trunkings with a 100% filling coefficient		
1 x 1,5	7,9	62,5	0,06	84	126	170
1 x 2,5	8,3	69	0,075	76	114	152
1 x 4	8,8	77,5	0,090	68	102	136
1 x 6	9,4	88,5	0,120	60	89	120
1 x 1,5	9,8	96	0,090	54	82	110
1 x 2,5	10,2	104	0,100	50	76	102
1 x 10	10,2	104	0,160	50	75	102
1 x 4	10,7	114,5	0,12	46	70	92
1 x 6	11,3	127,5	0,15	41	62	83
1 x 16	11,8	139	0,24	38	57	76
1 x 10	12,1	146,5	0,20	36	64	72
1 x 25	13,6	185	0,35	28	43	57
1 x 16	13,7	187,5	0,28	28	42	56
1 x 35	14,8	219	0,46	24	36	48
1 x 25	15	225	0,39	23	35	47
1 x 35	16,3	265,5	0,50	20	30	40
1 x 50	17,2	296	0,62	18	27	36
1 x 70	19,5	380	0,85	14	21	28
1 x 95	22,3	497	1,17	10,4	16	22
1 x 120	24,3	590,5	1,38	9	14	18
1 x 150	26,3	691,5	1,67	8	11	15

Descrizione / Description				DMC10	DMC15	DMC20
Dimensioni ester. canale con coperchio mm Outer size of trunking with cover mm				100 x 62,5	150x62,5	200x62,5
Sezione geometrica mm ² Geometric section mm ²				5.200	7.900	10.600
Peso canale dal-m Trunking weight dal-m				1,60	2,00	2,350

Tipo cavo N. conduttori x sez. nominale Type of cable N. ducts x rated section	Ø est. cavo mm. Outer Ø of cable mm	Sez. necessaria per un cavo mm ² Necessary section x 1 cable mm ²	Peso cavo Weight cable dal-m.	Numero cavi contenuti nei canali con coeff. di riempim. 100% Number of cable contained within trunkings with a 100% filling coefficient		
1 x 185	28,8	829,5	2,06	7	10	13
1 x 240	1,9	1017,5	2,66	5	8	10,4
1 x 1300	35,2	1239	3,29	4,2	6,4	8,6
2 x 1,5	13,2	174	0,18	30	45	61
2 x 2,5	14,5	210	0,23	25	38	60
2 x 4	15,8	249,5	0,295	21	32	42
2 x 6	17	289	0,36	18	27	37
2 x 10	18,6	346	0,485	7	23	31
2 x 16	22,2	493	0,72	10,6	16	21
2 x 25	26,5	702	1,09	7,4	11	15
2 x 35	28,9	835	1,38	6,4	9,4	13
2 x 50	31	961	1,69	6	8,4	11
2 x 70	35	1225	2,229	4,4	6,4	9
3 x 1,5	12,7	161	0,18	33	49	66
3 x 2,5	13,6	185	0,23	28	43	57
3 x 4	14,7	216	0,29	24	37	49
3 x 6	16,4	269	0,39	20	29	40
3 x 10	18,2	331	0,54	16	24	32
3 x 16	22,4	502	0,85	10,4	16	21
3 x 25	26,3	691,5	1,26	7,6	11,4	15
3 x 35	29	841	1,63	6,2	9,4	13
3 x 50	33,3	1109	2,18	4,8	7,2	10

*N.B.) Il riempimento del canale non deve superare il 50% della sezione geometrica (Norme CEI 23-32).
*N.B. Filling of the trunking must not exceed 50% of the geometric section (CEI 23-32 standards).

Diagramma di flessione canali sottoposti ad un carico uniformemente distribuito in dalN.
Diagram illustrating trunking bending when submitted to a uniformly distributed load in dalN.

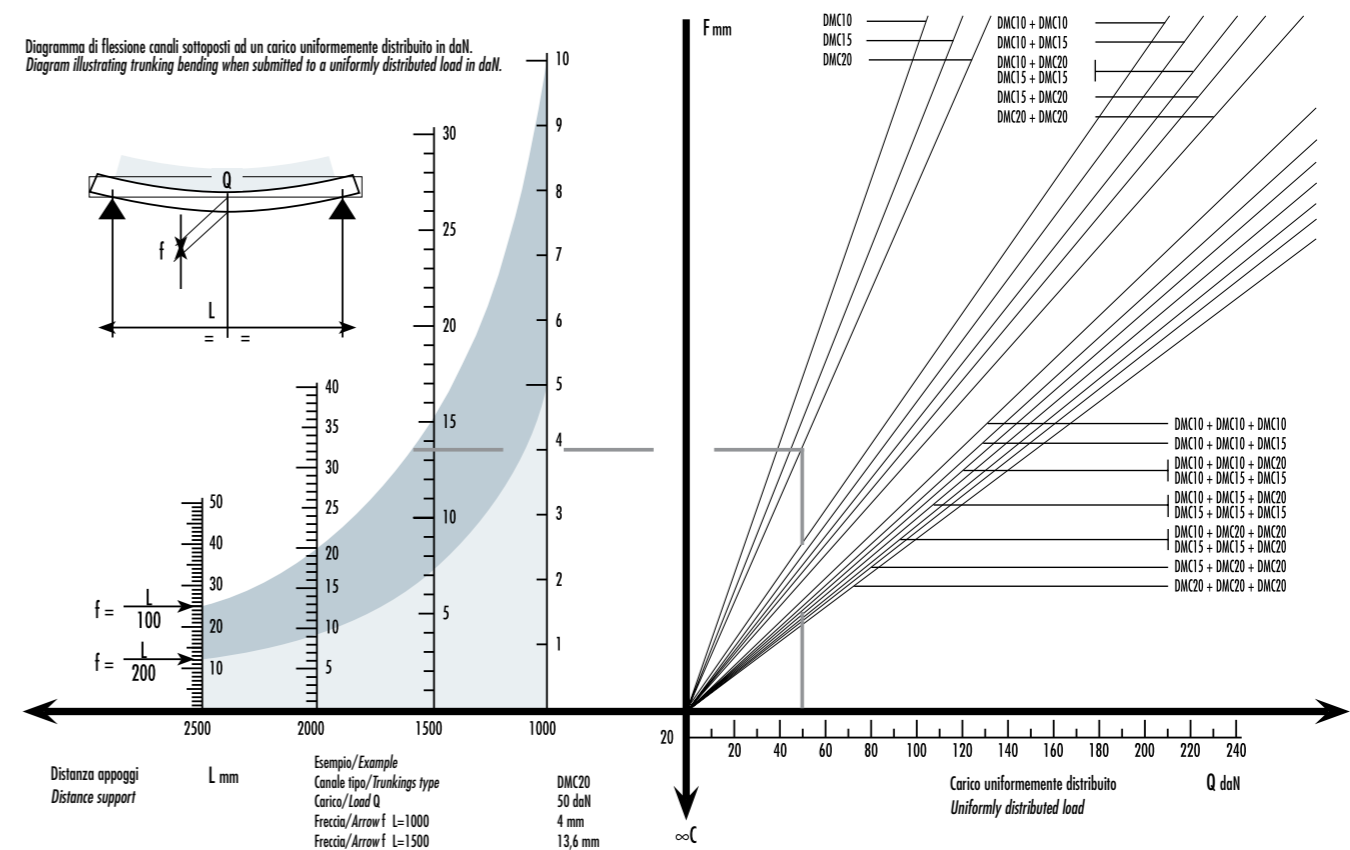

LDS50 / DMT / DMF

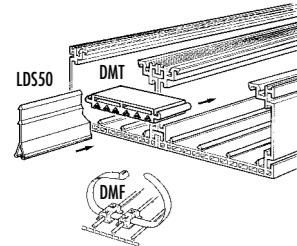

Si incastrano nelle apposite sedi del fondo e delle pareti laterali.
These are assembled by fixing them in the special rails on the bottom and on the side walls.

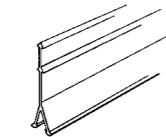

LDS50
Separatore.
Separator.

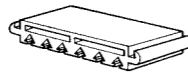

DMT
Traversino per trattamento
cavi e separatore.
Cross arm for cables
and separators retention.

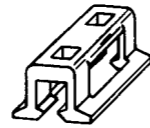

DMF
Porta fascette.
Cable-tie holder.



DMCG

Coprigiunto coperchi.
Si incastra tra i coperchi.
Cover for joint between covers.
This must be stuck between
the covers themselves.

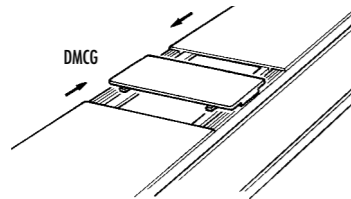

DM050

Giunzione tra due canali.
1 kit contiene:
- 1 Giunto DX
- 3 Giunti fondo canale
- 1 Giunto SX
Coupling between
two trunkings.
1 kit contains:
- 1 right-hand joint
- 3 trunking base joints
- 1 left-hand joint

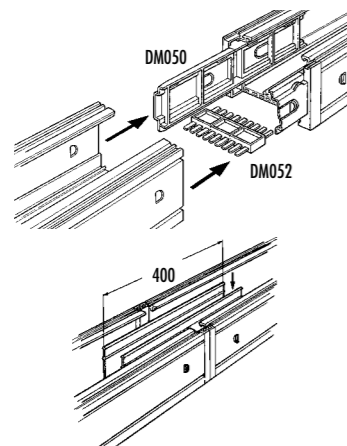

Si consiglia la giunzione tra i due canali a un 1/5 della distanza L tra le mensole.
Coupling the trunking at 1/5 of the L distance between the brackets.

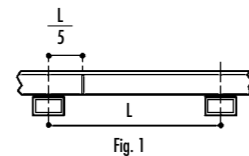

Forare le pareti dei canali ed inserire i giunti DM050 nelle guide laterali. Posizionare negli alveoli del fondo i giunti DM052. Accostare le testate dei canali. N.B. Per un ulteriore irrigidimento incastrare sulle guide del fondo, in modo equidistante, uno o più spezzoni di separatore LDS50 lunghi 40 cm.
Bore trunking walls and insert DM050 couplings in inner guides. Place DM052 couplings on bottom rails.
Then put heads of trunking near. P.N. Further stiffness is obtained by fixing on bottom guides, at regular intervals, one or more pieces of LDS50 separator, 40 cm in length.



DMCP-DM055

Giunzione tra curva e canale.
1 kit contiene:
- 4 Giunti canale Dx+Sx
- 5 Giunti fondo/curva
- 4 Profili giunto canale
Coupling between bend
and trunkings. 1 kit contains:
- 4 right-hand+left-hand trunking joints
- 5 base/bend joints
- 4 trunking joint profiles

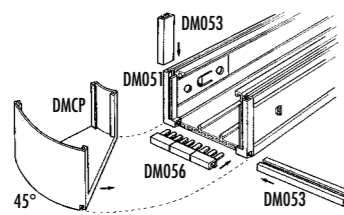

Forare le pareti dei canali ed inserire i giunti dx e sx DM051 nelle guide laterali interne ed i giunti DM056 negli alveoli del fondo. Accostare al canale la curva a 45° DMCP ed innestare nei giunti laterali del fondo, i profili di giunzione DM053 spezzandoli secondo necessità.
Bore trunking walls and insert right and left DM051 couplings in side guides (inner) and DM056 couplings on bottom rails.
Put 45° elbow DMCP near trunking and connect side couplings with DM053 couplings, cutting them according to requirements.

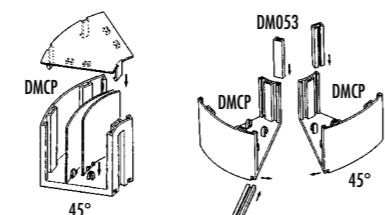

Accostare tra loro 2 o più curve a 45° DMCP sino ad ottenere la curva desiderata e innestare sulle pareti e sul fondo i profili di giunzione DM053 spezzandoli secondo la necessità.
Near two or more 45° DMCP bend until the required bend is obtained, then connect DM053 couplings to walls and bottom, cutting them according to requirements.



Max raggio curvatura cavi	
Max cables bending radius	
DMCP10	240mm
DMCP15	400mm
DMCP20	580mm

DM270

Giunzione a «T».

1 kit contiene:
- 2 Raccordi «T» Dx-Sx
- 1 Giunto fondo canale
- 1 Accessorio non promiscuità «T» coupling.
1 kit contains:
- 2 right-hand/left-hand T joints
- 1 trunking base joint
- 1 cable non-contact accessory

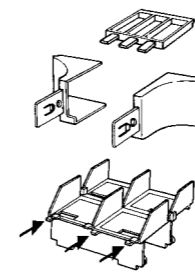

Fratturare le linguette verso la parete chiusa del canale.
Fracture the strips towards the closed part of the trunking.

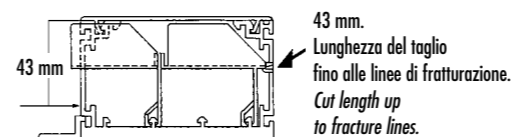

Max raggio curvatura cavi.
Max cables bending radius.

400 mm	500 mm	320 mm
200	200	150
100	150	100

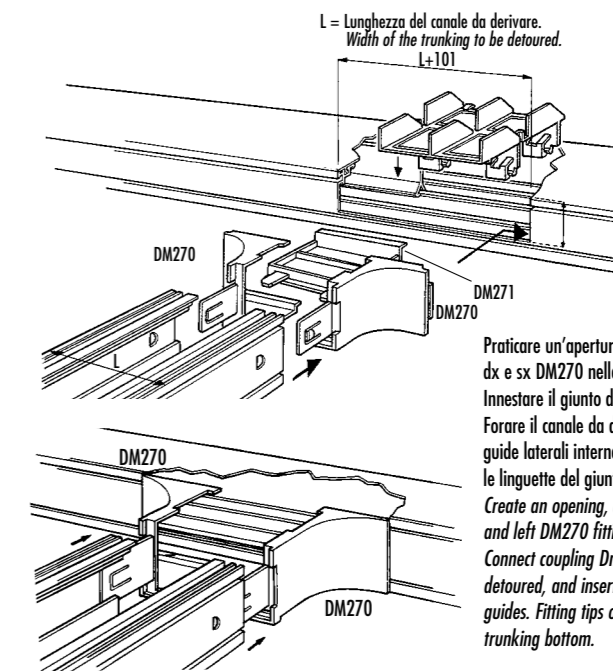

Praticare un'apertura come da figura. Inserire i raccordi dx e sx DM270 nelle guide laterali interne del canale. Innestare il giunto di collegamento DM271 (vedi figura). Forare il canale da derivare e inserire i giunti dx e sx nelle guide laterali interne. Accostare tra loro i canali innestando le linguette del giunto DM271 nelle sedi del canale.
Create an opening, according to drawing. Insert right and left DM270 fittings in inner side guides of trunking. Connect coupling Dm271 (see figure). Bore trunking to be detoured, and insert right and left couplings in inner side guides. Fitting tips of DM271 coupling in rails on trunking bottom.

Spezzare l'accessorio di separazione cavi come illustrato. Split the cable non cross over accessory as shown.

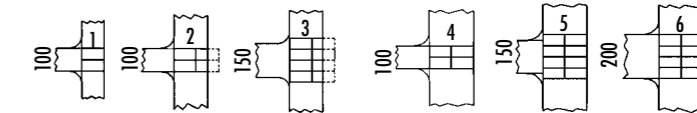

DM060P

Giunzione snodata per discesa a 90°

1 kit contiene:
- 2 Giunti DX
- 2 Viti nylon Ø 8 mm
- 2 Giunti SX
- 2 Dadi nylon
Articulated joint for 90° lowering.
1 kit contains:
- 2 right-hand joints
- 2 Ø 8 mm nylon screws
- 2 left-hand joints
- 2 nylon nuts

Istruzioni per il montaggio. Assembly instructions.

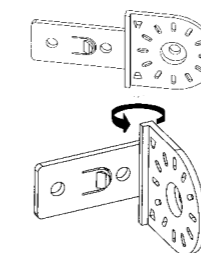

DM060-INT
Riscaldare la parte con aria calda fino a poter effettuare una piega a 90° come mostrato in figura.
Heat with hot air the part until it bends 90° as showed in the picture.

A. Tagliare la parete del canale per un'altezza di 50 mm ed una larghezza "L" pari alla base del canale utilizzato per la discesa.
Cut the wall of the trunking for an height of 50 mm and a width "L" equal to the base of the trunking used for the lowering.
B. Inserire lungo le guide predisposte all'interno della parete i due accessori DM060-INT precedentemente piegati a 90°.
Connect the two DM060-INT 90° crooked accessories along the predisposed rails inside the wall.

C. Tagliare un pezzo di canale da 250 mm e praticare con l'attrezzo DMU i fori per applicare il DM060-kit all'estremità, fissare alla parte precedentemente preparata con i due bulloni in dotazione.
Cut a piece of the trunking 250 mm and with the tool DMU make the holes to fix DM060-kit at the ends, fix the to the part already prepared with the two bolts provided.

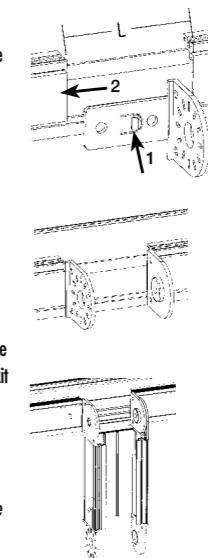

D. Tagliare un pezzo di canale da 200 mm e procedere come sopra collegandolo al precedente con un'inclinazione di 30°.
Cut a piece of the trunking 200 mm long and proceed as above connecting it to the previous one with a 30° inclination.
E. Collegare, sempre utilizzando il DM060, con il canale a parete.
Connect with the trunkings at the wall by using DM060.
F. Dopo aver fatto transitare i cavi procedere alla chiusura con i coperchi e gli accessori DMSN.
After having pulled the cables, proceed with the closure with the covers and the accessories DMSN.

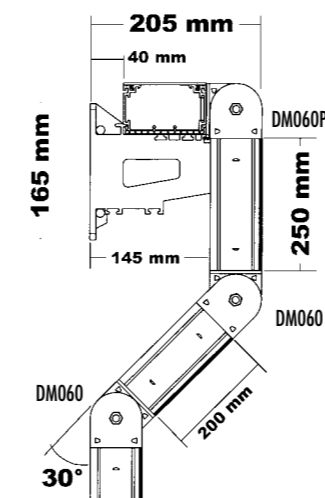
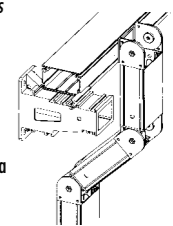

DM060-DMSN

Giunzione snodata.

- 1 kit contiene:
- 2 Giunti DX
- 2 Viti nylon Ø 8 mm
- 2 Giunti SX
- 2 Dadi nylon

Articulated joint.

- 1 kit contains:
- 2 right-hand joints
- 2 Ø 8 mm nylon screws
- 2 left-hand joints
- 2 nylon nuts

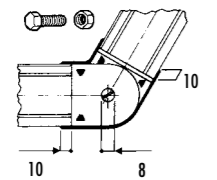

Max raggio curvatura cavi 150 mm
Max cables bending radius

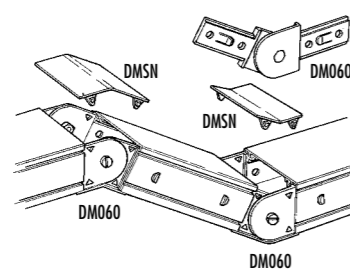
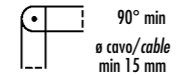

Forare le pareti dei canali. Inserire nelle apposite guide laterali interne i giunti DM060 (30°-45°-60°-90°). Fissare i canali alle mensole o ai supporti e bloccare gli snodi. Dopo aver montato i coperchi applicare a scatto i coprigiunti DMSN (30°-45°-60°-90°).
Bore trunking walls. Insert DM060 couplings (30°-45°-60°-90°) in specifically intended side guides. Fix trunkings to brackets or support and block articulated couplings. After assembling the covers, clip on the DMSN coupling covers (30° - 45° - 60° - 90°).

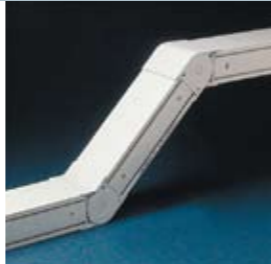

DM090-DM075

Placca portamostrine e mostrina per magnetotermici orizzontali completa di:

- Coperchio trasparente
- Profilo Omega
- 3 viti met. di fissaggio
- Distanziale

Panel point plackets and panel for horizontal magnetothermic devices.

- With:
- Transparent cover
- Omega profiling
- 3 metal attachment screws
- Spacer

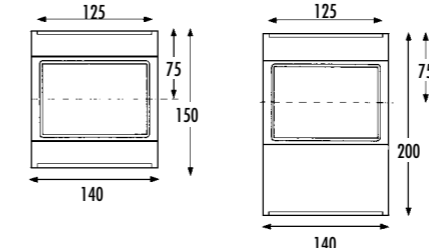

Le placche porta mostrine DM0902 e DM0903 permettono il montaggio della mostrina DM075 (con distanziatore). Si incastrano a scatto sui canali DMC15 e DMC20.
The panel point plackets DM0902 and DM0903 can take panel DM075 (with spacer). Click on the DMC15 and DMC20 trunkings.

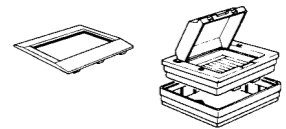

DMPU

Coperchi pretranciati per apparecchiature con interasse 108 mm.

Pre-cut covers for equipments with interaxis 108 mm

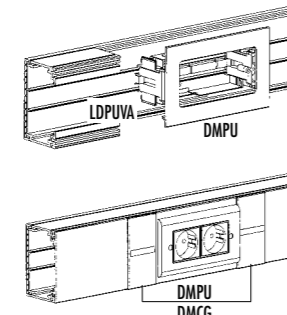
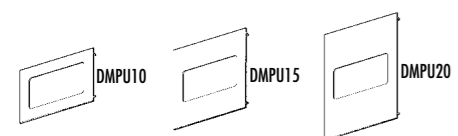

Per inserire sui canali DMC10, DMC15 e DMC20, apparecchiature con interasse 108 mm. Si usa con il supporto variabile LDPUVA. For mounting on DMC10, DMC15 and DMC20 trunkings equipments with interaxis 108 mm. Use with variable support LDPUVA.



DM180

Scatola di derivazione - 125x125x83 mm

- Completa di:
- 1 accessorio non promiscuità cavi
- 4 pareti laterali
- 1 mostrina DM071
- 6 viti fissaggio

Junction box. 125x125x83 mm

- With:
- 1 cable non-contact accessory
- 4 side section
- 1 DM071 plate
- 6 fixing screws

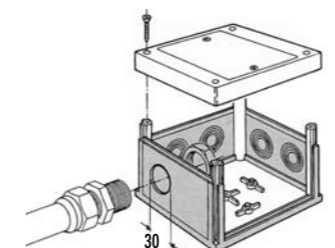

Max 2 tubi Ø esterno 30 mm per ogni parete.
Max 2 ducts Ø outer 30 mm on every side sections.

Utilizzo della scatola DM180 come portautenza. Anche per DM280. Utilization of DM180 box as socket point. For DM280 too.



LDPUVA

Supporto portautenze.

Socket point support.

Sezione d'ingombro 1780 mm² da detrarre dalla sezione del canale.
Section 1780 sq. mm to be subtracted from usable trunking section.

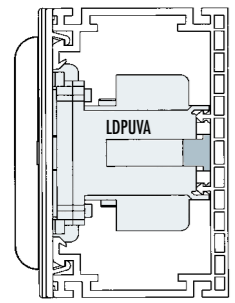

Montaggio sui canali DMC10, DMC15 e DMC20 di apparecchiature con interasse 108 mm
Mounting on DMC10, DMC15 and DMC20 trunkings of equipments with interaxis 108 mm

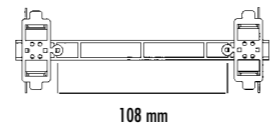
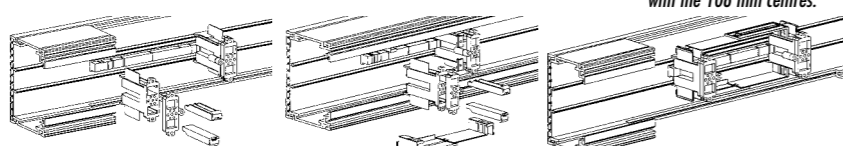

Posizionare i due blocchetti in corrispondenza dell'interasse 108 mm
Fix the two blocks in connection with the 108 mm centres.



Vedere il foglio istruzioni per il montaggio.
See the mounting instructions sheet.

DM280

Scatola di derivazione - 250x125x83 mm

- Completa di:
- 2 accessori non promiscuità cavi
- 6 adattatori
- 2 mostrine DM 071
- 2 perni DM286
- 10 viti di fissaggio

Junction box. 250x125x83 mm

- With:
- 2 cable non-contact accessory
- 6 adaptors
- 2 DM071 plate
- 2 DM286 pins
- 10 fixing screws

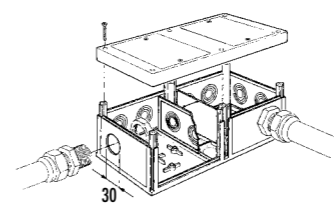

Max 2 tubi Ø esterno 30 mm sulle mostrine e 3 spie luminose Ø 30 mm sul coperchio.
Max 2 ducts Ø outer 30 mm on the panels and 3 pilot lights on the cover.

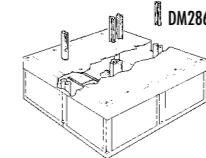

Accoppiamento di più scatole. Inserire nelle guide predisposte sulle basi, i perni DM286.
Coupling of several junction box. Insert pivots DM286 into the prefitted guides in the bases.

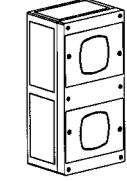

DM105

Porta apparecchiature modulari (17,5).

Permette il montaggio, in modo separato, su canali DMC15 - DMC20 di apparecchiature con modulo 17,5 (interruttori magnetotermici o altre) montabili su guida DIN 46277/3. Modular equipments units (17,5) point.

It can take 17,5 module equipments (e.g. thermomagnetic switches) which can be fitted to a DIN 46277/3 guide separately installed on DMC15 - DMC20 trunking.

116x59x40 mm

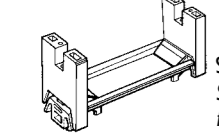

Sezione d'ingombro 1780 mm²
Section 1780 sq. mm to be subtracted from usable trunking section

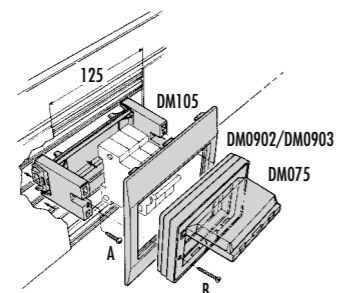

Fissare il porta apparecchi modulari agganciandolo alle guide del canale con 2 viti (A). Inserire a scatto sulla sua guida metallica le apparecchiature modulari. Accostare i coperchi del canale e montare a scatto, sul canale stesso, la placca portamostrine. Fissare la mostrina con distanziatore al porta apparecchiature con 2 viti (B).
Secure modular equipment point to trunkings guides using two screws (A). Click modular equipment units into place onto metal guide. Position trunking covers and click panel plate into place. Secure panel with spacer to equipment points using two screws (B).



DM281

Derivazione di canali DMC dalle scatole DM180/280.
DMC trunking junction with DM180/280 boxes.

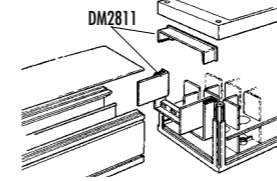

Entrata canali / Entry of the trunkings	
A	N. 1 - base 100 mm
B	N. 2 - base 100 mm
	N. 1 - base 150 mm
	N. 1 - base 200 mm

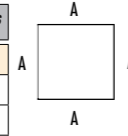

Inserire nelle guide predisposte sulle basi i raccordi inferiori, innestare i canali nei raccordi, inserire nelle stesse guide i raccordi superiori e fissare il coperchio con le viti.
Insert lower joints into the pre-fitted guides in the bases, slide trunkings into joints, insert upper joints into the same guides and secure the lid using the screws.

Solo per DM280 / Only for DM280

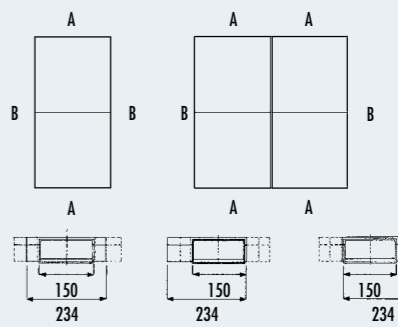

DM2812 - Fratturando le parti annerite è possibile variare la posizione d'ingresso del canale.
DM2812 - Trunking entry can be change by splitting black areas.

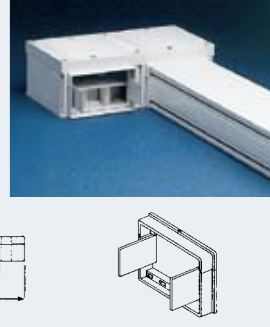

DM300 / DM301 / DM322

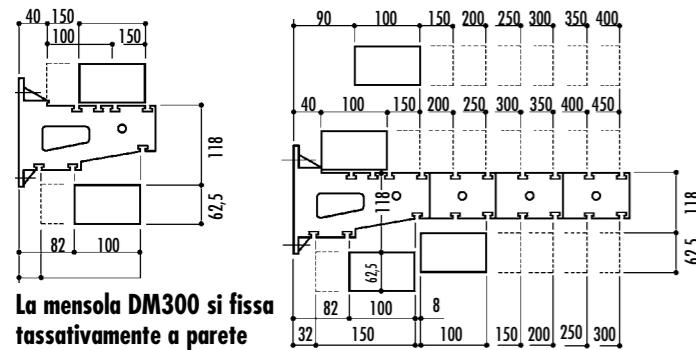

La mensola DM300 si fissa tassativamente a parete con 4 tasselli M8. The DM300 bracket must be fixed to the wall with 4 M8 wall plugs.

La prolunga DM301 va compressa nella mensola e ancorata con il perno DM322. The DM301 extension must be compressed into the bracket, and fastened with pivot DM322.

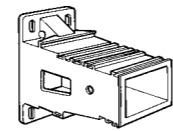

DM300
Mensola di sostegno.
Bracket. 80x200x150 mm

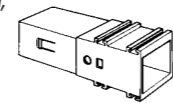

DM301
Prolunga per mensola DM300.
Extension for DM300 bracket.

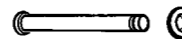

DM322
Perno. Pivot. Perno per il fissaggio della prolunga alla mensola e della mensola al canale Omega DM321. Pin for fixing extension to bracket and bracket to DM321 Omega trunking.

DM303

Fissaggio del canale sulla mensola. Fixing the trunking on the bracket.

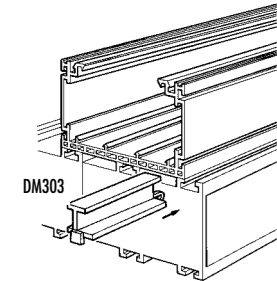

Posizionare una parete del canale sul riscontro fisso della mensola ed inserire la graffa DM303 per la tenuta. L'utilizzo dell'accessorio oltre alla tenuta del canale consente, al canale stesso, lo scorrimento dovuto alla dilatazione lineare. Put on wall of the trunking on the fixed part of the bracket DM303 fastening clip for support. The use of the accessory and the closing of the trunking allows for movement due to the linear expansion.

Combinazioni possibili di accoppiamento canali/mensole e carichi uniformemente distribuiti in daN. Possible combinations of trunkings with brackets and uniformly distributed max acceptable loads expressed in daN.

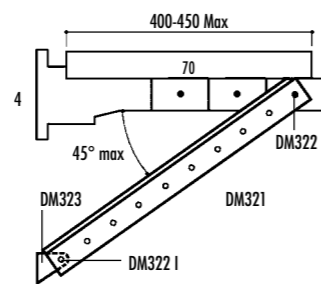
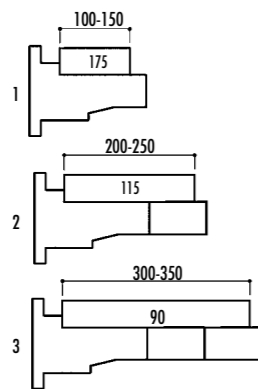

Con l'impiego del canale Omega le mensole possono portare tutto il carico max ammesso dal canale con riempimento al 50%. Per il montaggio del canale Omega DM321 e la staffa DM323 vedere pag. 2.6.20 e 2.6.21. By using the Omega trunking (Fig. 4), the brackets can support the entire max. acceptable load for the trunking when it is 50% filled. For assembling the DM321 Omega trunking and DM323 stirrup, see page 2.6.20 e 2.6.21.

DM304

Sostegno del canale sotto la mensola. Trunking support under bracket.

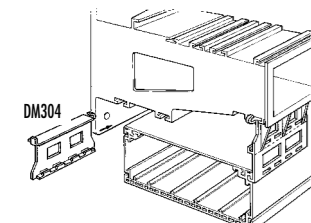

Inserire le graffe DM304 nelle sedi laterali del canale e successivamente nelle guide della mensola. L'utilizzo dell'accessorio oltre alla tenuta del canale consente, al canale stesso, lo scorrimento dovuto alla dilatazione lineare. Si consiglia di montare un traversino di tenuta cavi in corrispondenza delle graffe. Insert DM304 suspension clips in side guides of trunking and then in guides under bracket. The use of the accessory and the closing of the trunking allows for movement due to the linear expansion. In correspondence to each clip, we suggest to assemble a cable-holding sleeper.

Combinazioni possibili di accoppiamento canali/mensole e carichi uniformemente distribuiti in daN. Possible combinations of trunkings with brackets and uniformly distributed max acceptable loads expressed in daN.

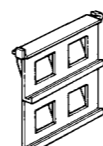
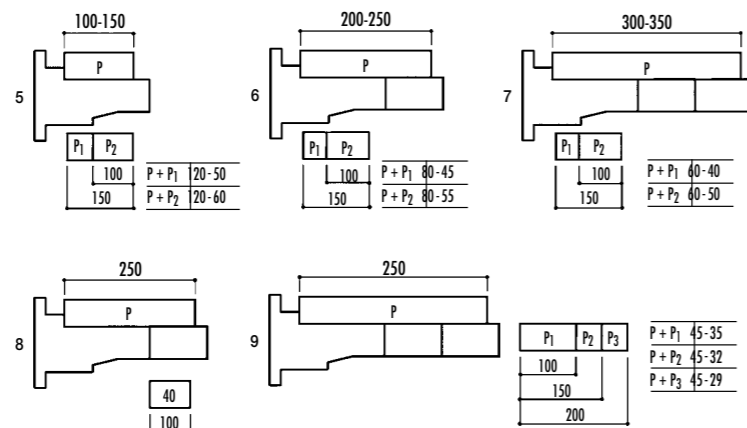

DM305

Sostegno del canale in verticale sotto la mensola. Vertical trunking support under bracket.

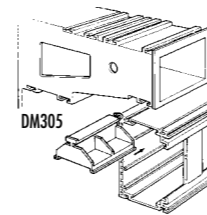

Inserire la graffa DM305 nelle sedi laterali esterne del canale e successivamente nella guida della mensola. Applicare un traversino DMT in corrispondenza delle graffe. L'utilizzo dell'accessorio oltre alla tenuta del canale consente, al canale stesso, lo scorrimento dovuto alla dilatazione lineare. Insert DM305 suspension clips in outer side grooves of trunking and then in guide under bracket. Assemble a DMT sleeper where the clips are. The use of the accessory and the closing of the trunking allows for movement due to the linear expansion.

Combinazioni possibili di accoppiamento canali/mensole e carichi uniformemente distribuiti in daN. Possible combinations of trunkings with brackets and uniformly distributed max acceptable loads expressed in daN.

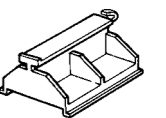
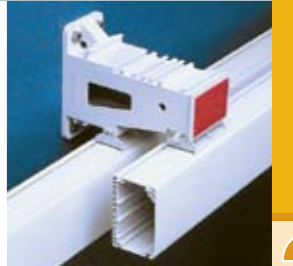
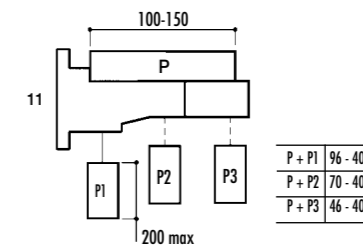
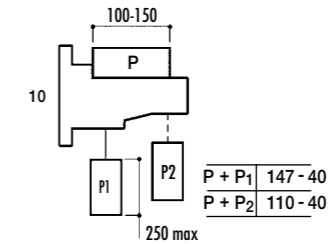

DMSO

Sospensione a soffitto di canali singoli. Suspension of single trunking from ceiling.

Inserire preventivamente sul canale gli accessori DMSO necessari al sostegno del carico da sopportare (vedi pag. 2.6.13). Applicare al soffitto il tassello filettato M8 o M10 per C.A. o altri adeguati al tipo di soffitto in funzione del supporto da appendere. Fissare con rondella e dado il tirante filettato al tassello, posizionare il supporto DMSO all'altezza voluta. N.B. Il supporto DMSO, in caso di aggiunta supplementare a canalizzazione posata, può essere inserito asportando la parte contrassegnata nella figura.

First fit the necessary DMSO accessories for supporting the required load into the trunking (see pag. 2.6.13). Fix M8 threaded wall plug to ceiling or M10 for reinforced-concrete, or another type suitable for the ceiling according to the support to be suspended. Fix the threaded stay rod to the wall plug with washer and nut, and fix support DMSO to the required height. P.N. - In the case of extra additions with the trunking already in position, the support can be fixed in by removing the part shown in figure.

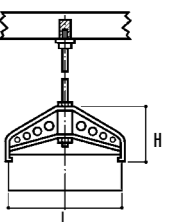
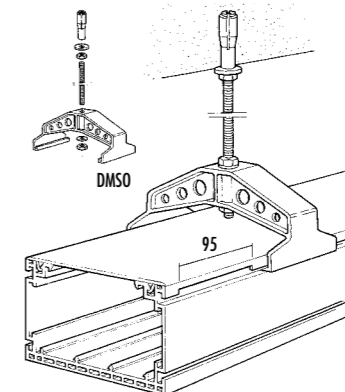

Tipo canale	Tipo supporto	L	H	carico max. daN
Type of trunking	Type of support			Max load daN
DMC10	DMSO10	100	75	50
DMC15	DMSO15	150	90	75
DMC20	DMSO20	200	100	100

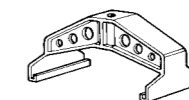

DMD

Fissaggio canale, a parete, con distanziatore.
Fixing trunking with spacer to the wall.

Fissare il distanziatore DMD con 2 rondelle e 2 viti M8 da avvitare nei due tasselli per C.A., o altri adeguati al tipo di parete. Posizionare una parte del canale sul riscontro fisso del distanziatore ed inserire la graffa DM303 per la tenuta e bloccare il canale con le due viti. Quando il canale è orizzontale montare sul medesimo, in corrispondenza del distanziatore un traversino di contenimento cavi DMT. L'utilizzo dell'accessorio oltre alla tenuta del canale consente, al canale stesso, lo scorrimento dovuto alla dilatazione lineare.
Fix DMD spacer with 2 washers and 2 M8 screws to be screwed into wall plugs for reinforced-concrete, or others suitable to the type of wall. Place one of the trunking walls against the fixer locator of the spacers, and insert DM303 stirrup for support; then fix the trunking is horizontal, assemble a cable-holding sleeper DMT near the spacer. The use of the accessory and the closing of the trunking allows for movement due to the linear expansion.

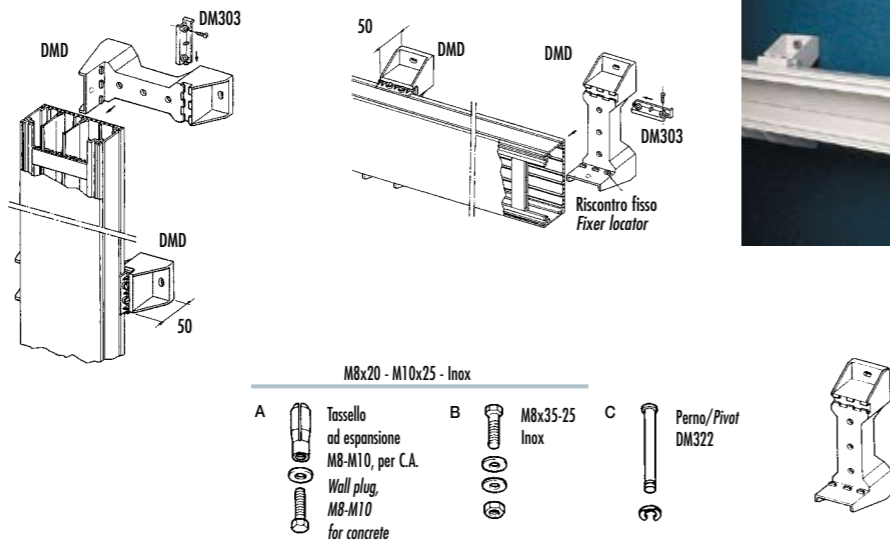

DMTR

Chiusura terminale del canale e riduzione.
Trunking end cap and reduction.

Forare le pareti del canale e inserire il tappo. In caso di derivazione con canali di sezione inferiore praticare l'apertura della dimensione desiderata servendosi delle apposite linee di fratturazione.
Bore trunking walls and insert the cap. In case of coupling with trunkings of smaller section, bore the hole of required size by using the expressly foreseen fracture lines.

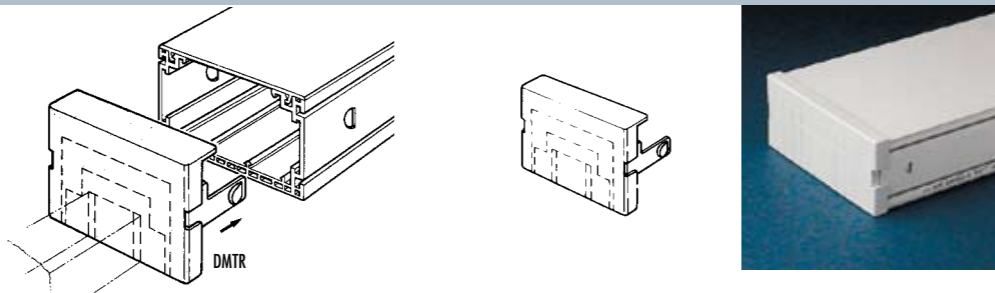

DM321

Sostegno di più mensole a parete.
Support of various brackets on the wall.
96x47 mm

Fissare a parete il profilo Omega o i distanziatori DMD con tasselli filettati M8 per C.A. o altri adeguati al tipo di parete. Posizionare la mensola con 2 perni DM322. Fissare il profilo Omega sui distanziatori DMD con due viti e dadi metallici M8x25.
Fix Omega trunking or DMD spacers to the wall with M8 threaded wall plugs for reinforced-concrete, or others suitable to the type of wall. Place with 2 DM322 pivots the bracket. Fix Omega trunking on the DMD spacers with 2 screws and metal nuts M8x25.

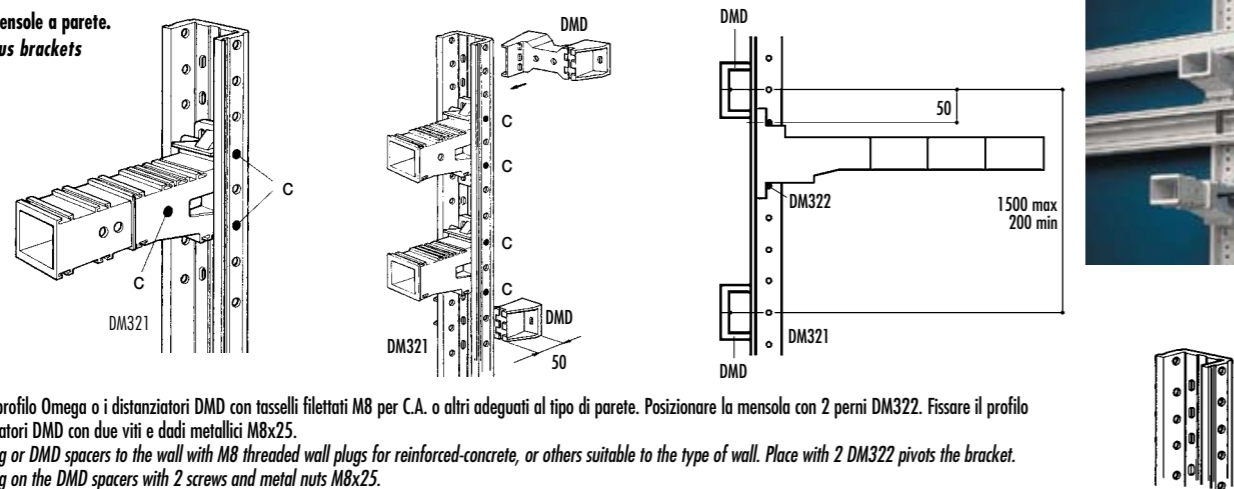

DM320+DM321+DM322

Fissaggio bilaterale a soffitto delle mensole.
Bilateral assembly of brackets to ceiling.

Fissare all'interno dei due profili Omega contrapposti due supporti DM320 con sei viti e dadi metallici M8. Fissare i supporti al soffitto con sei tasselli filettati M10 per C.A. o altri adeguati al tipo di soffitto. Posizionare la mensola con 2 perni DM322. Fissare le mensole con 4 viti e dadi metallici M8.
Fix two DM320 supports inside the two opposed Omega trunking, by using 6 screws and M8 metal nuts. Fix supports to ceiling with six M10 threaded wall plugs for reinforced-concrete, or others suitable to the type of ceiling. Place with 2 DM322 pivots the bracket. Fix brackets with 4 screws and M8 metal nuts.

Carico max. 600 daN.
Per i carichi da applicare alle mensole (vedi pag. 2.6.13) la somma totale non deve superare 600 daN.
Max load 600 daN
For bracket loads please see page 2.6.13 the total load must not exceed 600 daN.

Carico max. 300 daN.
I carichi indicati sono solo un'esempio per arrivare a 300 daN. Onde evitare inflessioni laterali del profilo Omega si consiglia l'equilibratura dei carichi che si ottiene:
carico sx. - carico dx. x 1,26.
Max load 300 daN
The loads indicated are just an exemple to obtain a total load of 300 daN. To avoid lateral bending of Omega trunking, it is best to balance the loads as follow: left load - right load x 1,26.

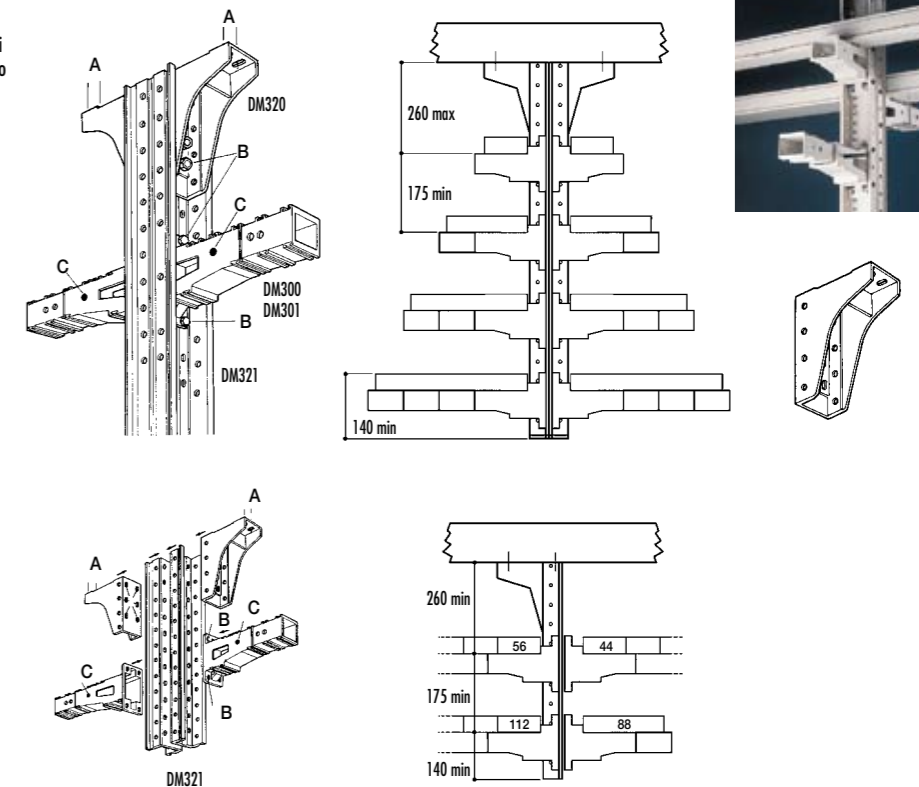

DM323+DM320+DM322

Fissaggio laterale a soffitto delle mensole.
Side fixing of brackets to ceiling.

Montare il profilo Omega al supporto DM320 con 6 viti e dadi metallici M8. Fissare il supporto al soffitto con 4 tasselli filettati M10 per C.A. o altri adeguati al tipo di soffitto. Montare la staffa DM323 al profilo Omega con 2 viti e dadi metallici M8 in corrispondenza dei due fori inferiori della mensola. Determinare la lunghezza del profilo Omega di contrasto e montarlo alla staffa DM323 con il perno DM322. Fissare al soffitto una staffa DM323 con due tasselli filettati M8 e infilare il perno DM322 nella staffa unitamente al profilo Omega. Per il posizionamento di più mensole collegare ciascuna mensola con l'Omega di contrasto come indicato in figura.
Assemble Omega trunking onto DM320 ceiling support with 6 screws and metal nuts M8. Fix support to ceiling with a threaded wall plugs M10 for reinforced-concrete or others suitable to the type of ceiling. Assemble DM323 stirrup onto Omega trunking with 2 screws and M8 metal nuts in correspondence with the two lower holes of the bracket. Fix length of apposite Omega trunking and assemble onto DM323 stirrup with pivot DM322. Fix one DM323 stirrup to ceiling with 2 M8 threaded wall plugs and put DM322 pivot in the stirrup together with Omega trunking. To fix many brackets, connect each one with a contrasting Omega trunking as shown in the drawing.

Carico max. 300 daN.
I carichi indicati sono solo un'esempio per arrivare a 300 daN. Onde evitare inflessioni laterali del profilo Omega si consiglia l'equilibratura dei carichi che si ottiene:
carico sx. - carico dx. x 1,26.
Max load 300 daN
The loads indicated are just an exemple to obtain a total load of 300 daN. To avoid lateral bending of Omega trunking, it is best to balance the loads as follow: left load - right load x 1,26.

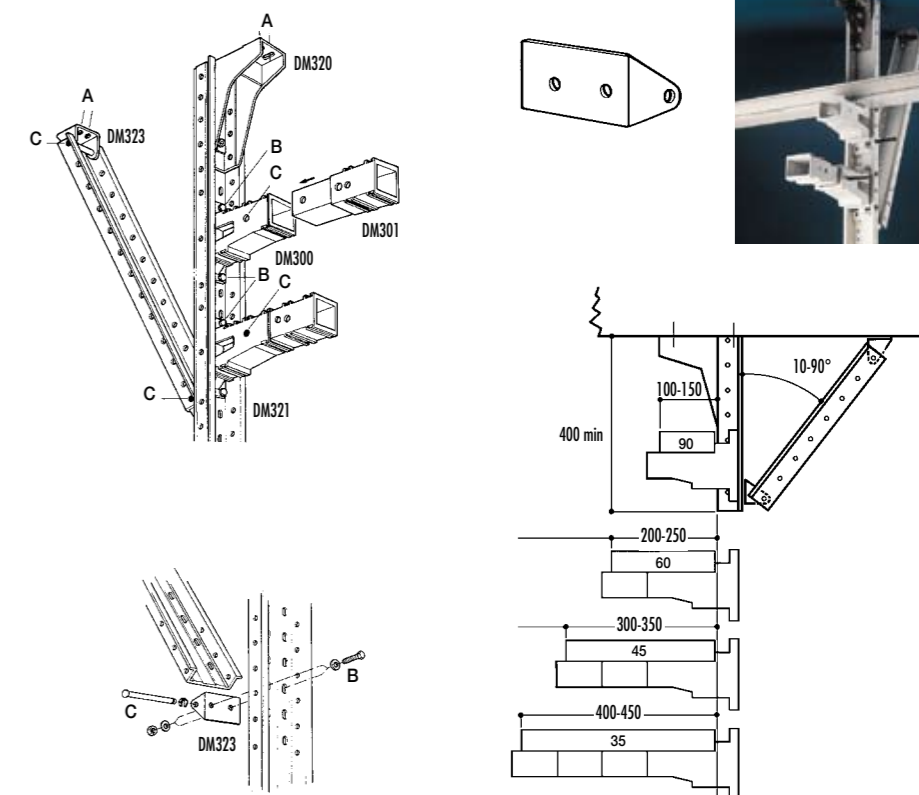

Dati tecnici. Technical data.

DMAI-DMAE

Giunzione a parete del canale con angolo interno/esterno.
Wall coupling of trunking with inner and outer bend.

Max raggio curvatura cavi 150 mm

Fissare le curve con uno o due tasselli (TS). Accostare il canale alla curva e bloccarlo con tasselli (TS). Inserire eventuali separazioni. Montare a scatto i coperchi del canale e successivamente il coperchio della curva. I coperchi si smontano con opportuno utensile.

Max cables bending radius 150 mm

Fix bends with on or two wall plugs (TS). Near trunking to bend and fasten it with wall plugs (TS). Insert any separating barriers required. Assemble trunking covers by snapping them on, then do the same with cover for bends. Covers may be removed by a tool.

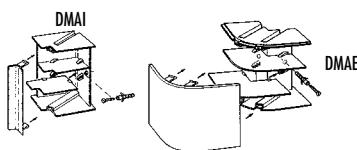
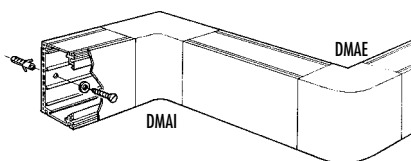
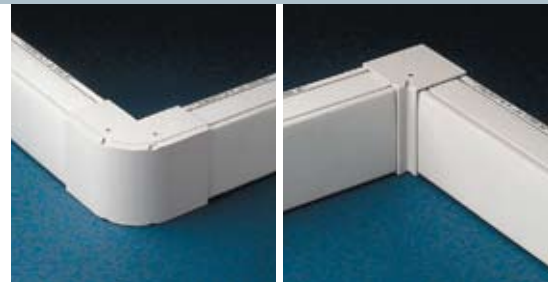

FMC

Fermacavo universale per canali H.60/80.

Applicato sulle guide dei canali impedisce lo spostamento accidentale dei cavi.

Può contenere 3 cavi (massimo 5mm di diametro) per ogni foro (2).

Universal cable-holder. For wire ducts H. 60/80.

Application on the built-in rail of the duct to avoid accidental pulling of the wires.

It can contain 3 wires (of maximum 5mm of diameter) for each hole (2).

